



Relief Modular Valve

13 to 79 gpm
3600 to 5000 psi

Features

This modular relief valve provides maximum pressure control for a hydraulic circuit.

Wide ranging applicability Maximum Operating Pressure: 3600 to 5000 psi Pressure Adjustment Range: 115 to 3600, 5000.

Shockless unload, 2-pressure control, and other configurations are possible by switching the solenoid valve. Contact your agent for details.

Specifications

Model No.	Nominal Diameter (Size)	Maximum Working Pressure psi	Maximum Flow Rate gpm	Pressure Adjustment Range psi	Weight lbs	Gasket Surface Dimensions
OR-G01-P1-20 P3	1/8	3600	13	* to 1000 500 - 3600	3.3	ISO 4401-03-02-0-94
OR-G01-W1-20 W3				* to 1000 500 - 3600	5	
OR-G01-A1-21 A3				* to 1000 500 - 3600	3.5	
OR-G01-B1-21 B3				* to 1000 500 - 3600	3.5	
OR-G03-P1-(V)-J50 P3	3/8	3600	21	* to 1000 500 - 3600	6.8	ISO 4401-05-04-0-94
OR-G03-W1-J50 W3				* to 1000 500 - 3600	8.6	
OR-G03-A1-J50 A3				* to 1000 500 - 3600	6.8	
OR-G03-B1-J50 B3				* to 1000 500 - 3600	6.8	
ORH-G04-P1-10 P3 P5	1/2	5000	79	* to 1000 500 - 3600 1000 - 5000	15.4	ISO 4401-07-06-0-94

Note: *See the Flow Rate - Low Pressure characteristics on page D-17 for information about items marked with an asterisk.

• Handling

- When using a remote control valve in a vent circuit, certain vent circuit pipe capacities can cause vibration. Because of this, thick steel pipe with an inside diameter of .15 in that is no longer than three meters is recommended. Vent piping cannot be used with the 01 size. If a vent port is required for the 03 size, add the auxiliary code "V".
- For use as a safety valve, use a pressure override that is higher than the required circuit pressure.
- Make sure that tank port back pressure is no greater than 29 psi.
- A small control flow rate can cause pressure instability. Use a control flow rate that is in accordance with the values shown below.
 - 01 size: At least 1.3 gpm
 - 03 size: At least 2.1 gpm
 - 04 size: At least 2.1 gpm

For applications that require a flow rate that is less than the minimum flow rate, use an ORD-G** direct type relieve modular valve.
- Note that a sub plate and installation bolts are not included. See pages H4 or F-87-89 if these items are required.
- 04 series modular valves do not have an L (DR drain port, so they cannot be used in combination with pressure center type solenoid valves (D).
- Connect OR-G03-W*-(J) 50 to the two T-ports on the tanks.

Understanding Model Numbers

01: 03 size

OR - G 03 - P 1 - (K) - J50

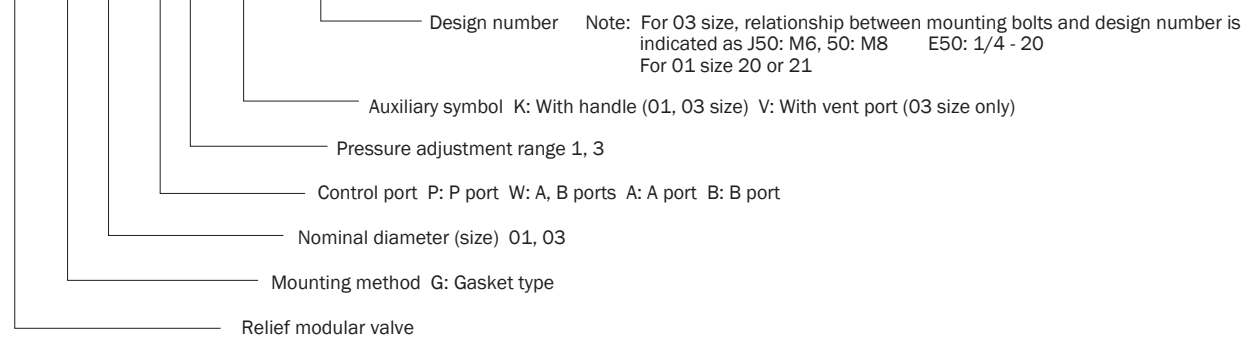

04 size

ORH - G 04 - P 5 - 10

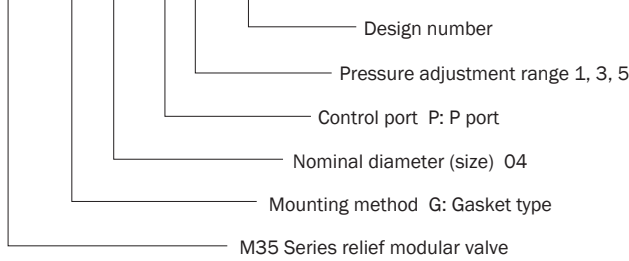

Installation Dimension Drawings

Note: Pressure is increased by clockwise (rightward) rotation of the adjusting screw (bolt), and decreased by counterclockwise (leftward) rotation.

OR-G01-P*-20

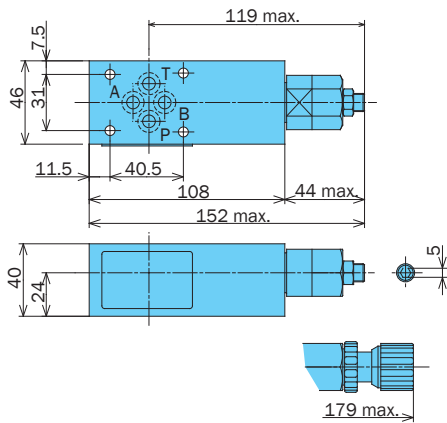

OR-G01-W*-20

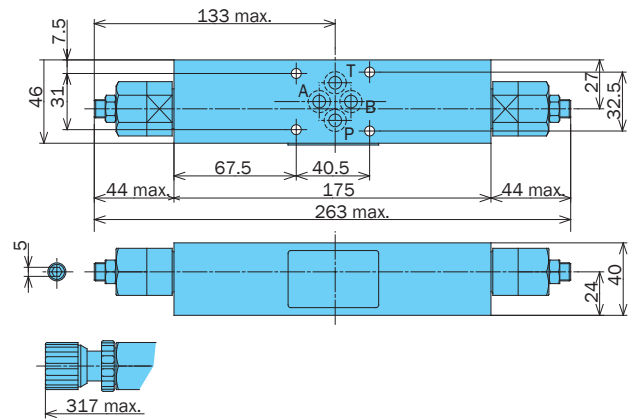

OR-G01-A*-21

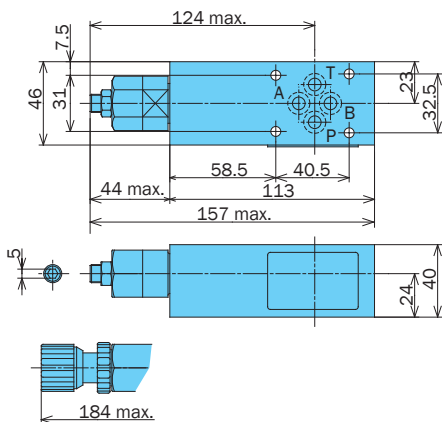

OR-G01-B*-21

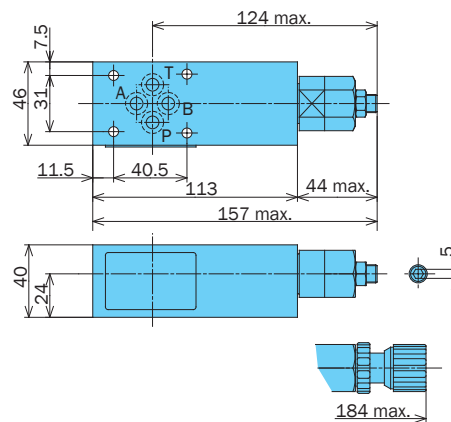

OR-G03-P*(V)-J50

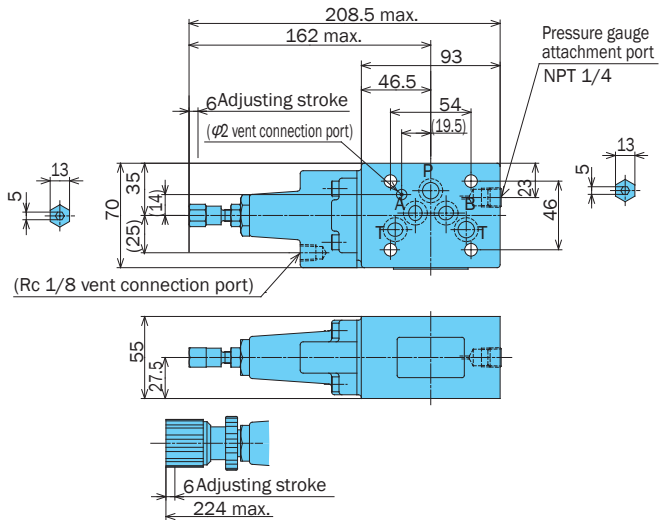

OR-G03-W*-J50

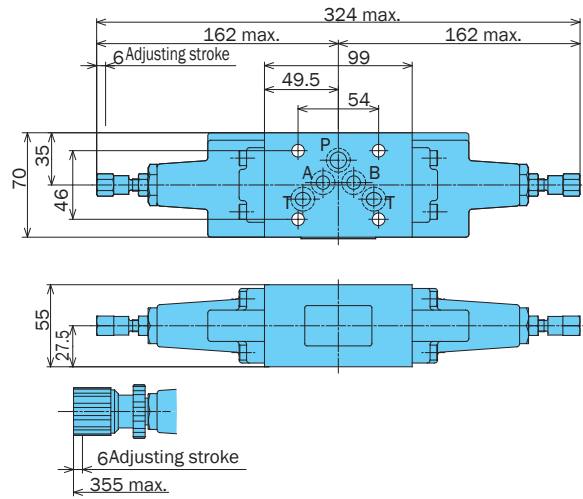

Note: Dimensions in parentheses show dimensions with vent port installed (V type)

OR-G03-A*-J50

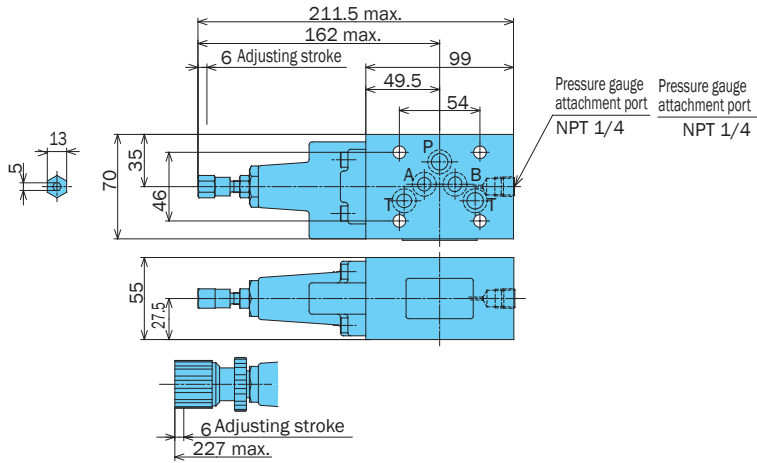

OR-G03-B*-J50

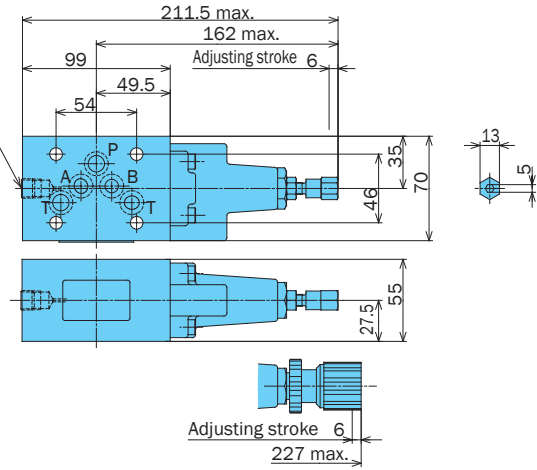

ORH-G04-P*-10

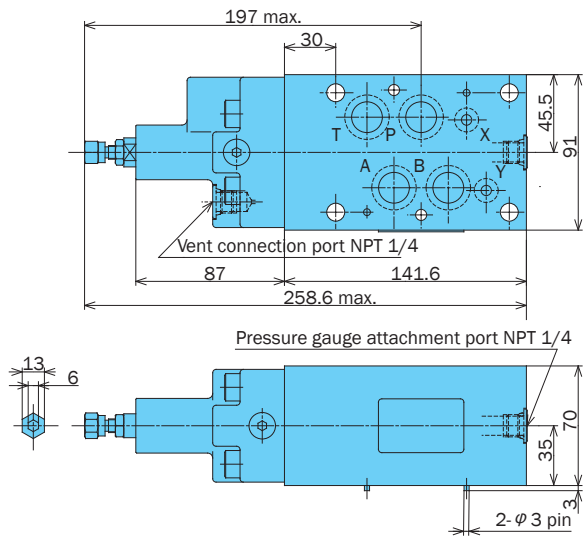

Performance Curves

Differential Hydraulic Fluid Viscosity 32 centistokes

Flow Rate - Minimum Pressure Characteristics

OR-G01-*1-20(21)

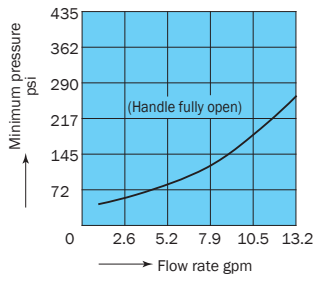

OR-G03-P1-J50

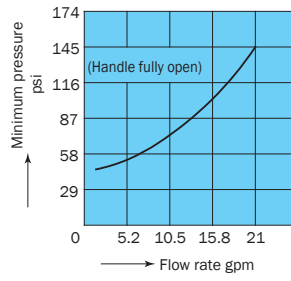

ORH-G04-P*-10

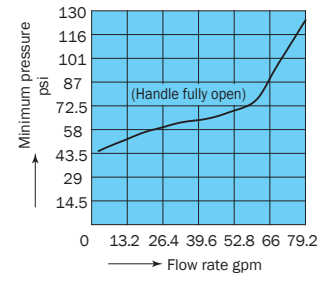

Pressure - Flow Rate Characteristics

OR-G01-* *-20(21)

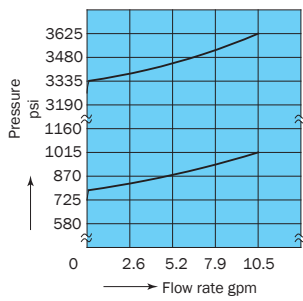

OR-G03-P*-J50

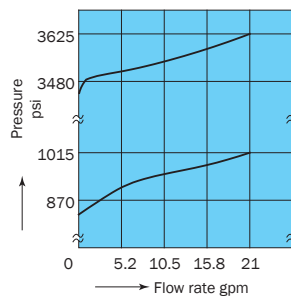

ORH-G04-P*-10

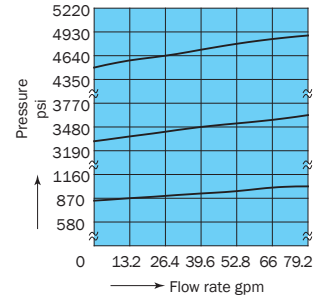

Number of Adjusting Screw Rotations - Pressure Characteristics

OR-G01-P*-20

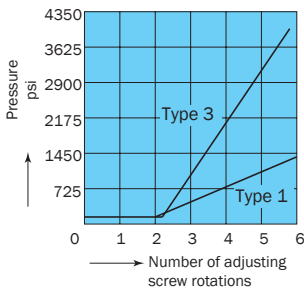

OR-G03-P*-(J)50

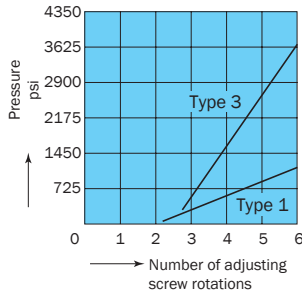

ORH-G04-P*-10

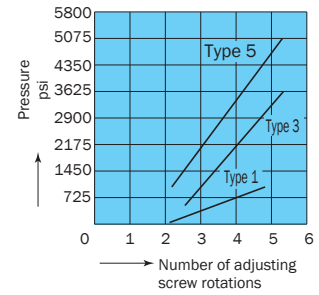

Cross-sectional Drawing

OR-G01-P*-20

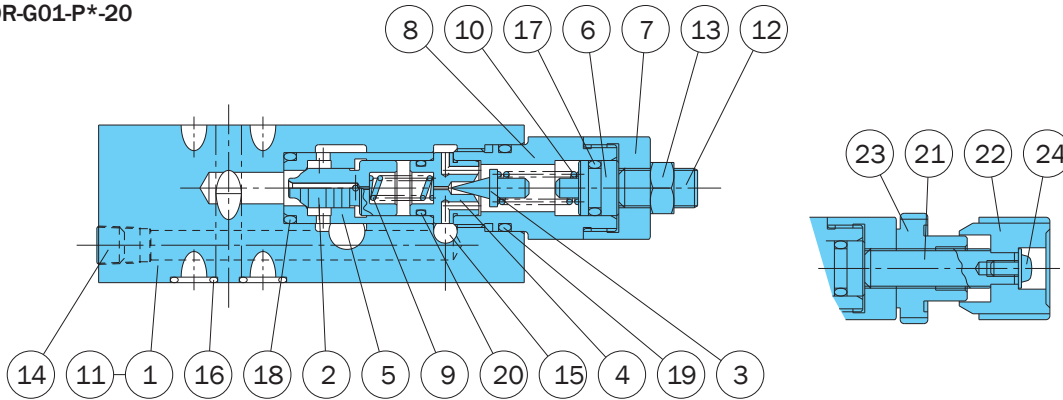

Part No.	Part Name
1	Body
2	Spool
3	Poppet
4	Seat
5	Sleeve
6	Plunger
7	Bushing
8	Retainer
9	Spring
10	Spring
11	Plate
12	Screw
13	Nut
14	Plug
15	Plug
16	O-ring
17	O-ring
18	O-ring
19	O-ring
20	O-ring
21	Screw
22	Knob
23	Nut
24	Screw

Seal Part List (Kit Model Number BRBS-01R*)

Part No.	Part Name	Part Number	Q'ty			
			P	W	A	B
16	O-ring	1B-P9	4	4	4	4
17	O-ring	1A-P10A	1	2	1	1
18	O-ring	1B-P14	1	2	1	1
19	O-ring	1B-P18	1	2	1	1
20	O-ring	AS568-013(Hs90)	1	2	1	1

Note) 1. O-ring 1A/B-** refers to JIS B2401-1A/B.
2. Specify P, W, A, or B for the asterisk (*) in the kit model number.

OR-G03-P*-V-J50

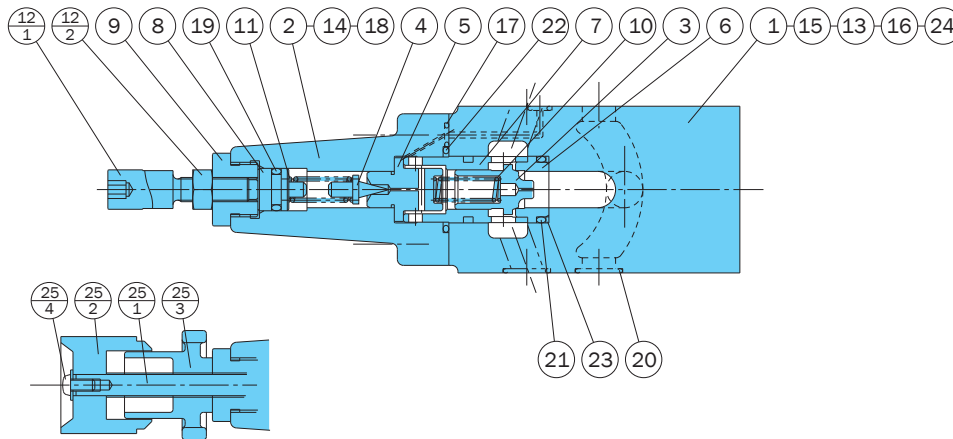

Part No.	Part Name
1	Body
2	Cover
3	Spool
4	Poppet
5	Seat
6	Seat
7	Sleeve
8	Plunger
9	Retainer
10	Spring
11	Spring
12	Screw kit
12.1	Screw
12.2	Nut
13	Plate
14	Screw
15	Plug
16	Plug
17	O-ring
18	O-ring
19	O-ring
20	O-ring
21	O-ring
22	O-ring
23	Backup ring
24	Pin
25	Handle kit
25.1	Screw
25.2	Knob
25.3	Nut
25.4	Screw

Seal Part List (Kit Model Number BRES-03R*)

Part No.	Part Name	Part Number	Q'ty		
			P/A/B	W	PV
17	O-ring	1B-P5	-	-	2
18	O-ring	1B-P7	1	2	1
19	O-ring	1A-P10A	1	2	1
20	O-ring	AS568-014(Hs90)	5	5	5
21	O-ring	1B-P18	2	4	2
22	O-ring	AS568-119(Hs90)	1	2	1
23	Backup ring	T2-P18	1	2	1

Note) 1. O-ring 1A/B-** refers to JIS B2401-1A/B.
2. Backup ring indicates JIS B2407-T2-**.
3. Specify P, W, or PV for the asterisk (*) in the kit model number.

ORH-G04-P*-10

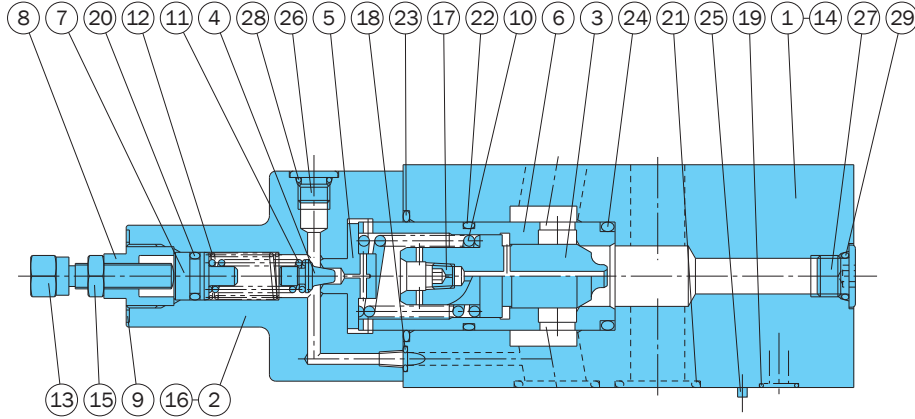

Part No.	Part Name
1	Body
2	Cover
3	Spool
4	Poppet
5	Seat
6	Sleeve
7	Plunger
8	Retainer
9	Plate
10	Spring
11	Spring
12	Spring
13	Screw
14	Plate
15	Nut
16	Screw
17	Choke
18	O-ring
19	O-ring
20	O-ring
21	O-ring
22	O-ring
23	O-ring
24	O-ring
25	Pin
26	Plug
27	Plug
28	O-ring
29	O-ring

Seal Part List (Kit Model Number BRKS-04RP)

Part No.	Part Name	Part Number	Qty
18	O-ring	1B-P5	1
19	O-ring	AS568-012(Hs90)	2
20	O-ring	1A-P11	1
21	O-ring	AS568-118(Hs90)	4
22	O-ring	AS568-122(Hs90)	1
23	O-ring	AS568-127(Hs90)	1
24	O-ring	1B-P28	1
28	O-ring	1B-P8	3
29	O-ring	1B-P11	3

Note) O-ring 1A/B-** refers to JIS B2401-1A/B.