

SA Series (Wiring System: DIN Connector Type) Wet Type Solenoid Valve 26.4 to 42 gpm
5075 psi

Features

Very long life
The movable iron core of the wet type solenoid is immersed in oil, which keeps it lubricated and cushions it from impact and vibration, ensuring very long life.

Low switching noise
The wet-type solenoid valve provides very low core switching noise, for quiet operation.

Shockless
A switching speed adjustment mechanism enables direct, shockless operation (Option F).

No surge voltage
Sparking and surge voltage during solenoid switching is canceled for stable switching (Option G).

Easy coil replacement
A DIN connector type coil enables one-touch coil replacement.

Wide-ranging backward compatibility
makes it simple to replace previous valve models with this one. Combining this valve with a modular valve contributes to the compact configuration of the overall device.

Global support (G01 size)
Meets overseas safety standards (CE, UL, and CSA). It can be safely used anywhere in the world. Contact your agent for certified products.

Specifications

Model No.		SA-G01 (D03)				SA-G03 (D05)					
		Standard Type		Shockless Type		Standard Type				Shockless Type	
		Maximum Flow Rate gpm	Maximum Working Pressure psi	Maximum Flow Rate gpm	Maximum Working Pressure psi	AC Solenoid Type		DC Solenoid Type (With built-in rectifier)		Maximum Flow Rate gpm	Maximum Working Pressure psi
Maximum Flow Rate gpm	Maximum Working Pressure psi					Maximum Flow Rate gpm	Maximum Working Pressure psi				
JIS Symbol	Operation Symbol										
	-A2X	7.9	5075	7.9	3625	10.5	5075	22.4	5075	22.4	3625
	-H2X										
	-E2X										
	-A3X	21.1	5075	21.1	3625	22.4	5075	5075	34.3	5075	3625
	-H3X										
	-E3X										
	-A3Z	17.1	5075	17.1	3625	34.3	5075	42.2	5075	34.3	3625
	-H3Z										
	-E3Z										
	-A4	13.2	5075	13.2	3625	34.3	5075	42.2	5075	34.3	3625
	-H4										
	-A5										
	-H5	26.4	5075	26.4	3625	34.3	5075	42.2	5075	34.3	3625
	-C2										
	-C5										
	-C9										
	-C1S										
	-C6S										
	-C1										
	-C6										
	-C4	13.2	5075	13.2	3625	18.4	3625	26.4	3625	22.4	3625
	-C7Y										
	-C8										

		SA-G01			SA-G03			
		AC Solenoid	DC Solenoid		AC Solenoid	DC Solenoid		
			Built-in Rectifier			Built-in Rectifier		
		C*	E*	D*	C*	E*	D*	
Maximum Working Pressure	P, A, B ports	5075 psi (Note 1)						
Maximum Allowable Backpressure	T port	3045 psi			2320 psi			
Switching frequency (cycles/minute)	Standard Type	300	120	300	300	120	240	
	Shockless Type	--		120			--	120
Option	Indicator light	R			R			
	Shockless	--	F		--	F		
	Surgeless	G	--	G	G	--	G	
	G Screw Connector	J	--	J	J	--	J	
	With manual push-button	N			N			
	Quick Return	--	Q	--	--	Q	--	
Weight (kg)	Double Solenoid	1.8	2.0		4.2	5.5		
	Single Solenoid	1.4	1.5		3.5	4.1		
Operating Environment	Dust Resistance/Water Resistance Rank	IP65 (Dust-tight, Waterjet-proof) (Note 2)						
	Ambient Temperature	-4 to 122°F						
	Operating Fluid	Temperature Range	-4 to 158°F					
		Viscosity Range	15 to 300 centistokes					
	Filtration	10 microns or less						
Mounting bolt	Size × Length	10-24 x 1 3/4 LG (not included)			1/4-20 x 2 3/4			
	Tightening Torque	3.6 to 5 ft lbs			7.3 to 9.5 ft lbs			

- Note: 1. Maximum operating pressure depends on the valve type. For details, see page D-16.
 2. The power supply type for E* is IP64 (dust-tight, splash-proof).
 3. For mounting bolts, use grade 8 or equivalent.
 4. Mounting bolts are not included with the O1 size. Bolts are included with the O3 size.

• Handling

- In order to realize the full benefits of the wet type solenoid valve, configure piping so oil is constantly supplied to the T port. Never use a stopper plug in the T port.
- Ensure that surge pressure in excess of the maximum allowable back pressure does not reach the T port.
- Note that the maximum flow rate is limited when used as a four-way valve, or by blocking ports for use as a two-way valve or one-way valve.
- Always keep the operating fluid clean. Allowable contamination is class NAS12 or less.
- When using petroleum type operating fluid, use ISO VG 32, 46.
- For details about using fire-resistant hydraulic fluid, contact your agent.
- Use this valve only within the allowable voltage range.
- Do not allow the AC solenoid to become charged until you install the coil into the valve.
- In the case of operation symbols A2X, H2X, and E2X, run drain piping from the valve T port.
- Maintaining a switching position under high pressure for a long period can cause

abnormal operation due to hydraulic lockup. Contact your agent when you need to maintain a switching position for a long period.

11 When using a detent type (E2X, 3X, E3Z), use constant energization in order to securely maintain the switching position.

RSA-***-AR*(H)-** ¹⁵ / ₂₃	SA-G01-AR-**-31
RSA-***-AQ*(H)-** ¹⁵ / ₂₃	SA-G01-A3X-**-31
RSA-***-*(F(H))-** ¹⁵ / ₂₃	SA-G01-A8X0-**-31

14 The coil surface temperature increases if this valve is kept continuously energized. Install the valve so there is no chance of it being touched directly by hand.

12 Note that manual pin operating pressure changes in accordance with tank line back pressure.

13 The series described in the table below are available for use as RSS and RIS Series solenoid control relief valves.

15 Use the following table for specification when a sub plate is required.

Model No.	Pipe Diameter	Maximum Working Pressure psi	Recommended Flow Rate gpm	Weight lbs	Applicable Valve Type
MSA-01X-E10	1/4	3625	5.2	2.6	SA-G01-***-**-E31
MSA-01Y-E10	3/8		7.9		
MSA-03-E10	3/8		11.8	5.0	SA-G03-***-**-E21
MSA-03X-E10	1/2		21.1		

• Solenoid Assembly Specifications

Solenoid Type	Power Supply Type	Voltage (V)	Frequency (Hz)	For SA-G01				For SA-G03					
				Solenoid Coil Type	Drive Current (A)	Holding Current (A)	Holding Power (W)	Allowable Voltage Range (V)	Solenoid Coil Type	Drive Current (A)	Holding Current (A)	Holding Power (W)	Allowable Voltage Range (V)
AC	C1	AC100	50	EAC64-C1	2.2	0.52	25	80 to 110	EBB64-C1	5.4	0.92	36.0	80 to 110
			60		2.0	0.38	22			90 to 120	4.6	0.62	
		AC110	60		2.2	0.46	28	5.0			0.78	42.0	90 to 120
	C115	AC110	50	EAC64-C115	2.0	0.47	25	90 to 120	EBB64-C115	5.0	0.85	36.0	90 to 120
			60		1.8	0.35	22			100 to 130	4.2	0.57	
		AC115	60		2.0	0.42	28	4.6			0.72	42.0	100 to 130
	C2	AC200	50	EAC64-C2	1.1	0.26	25	160 to 220	EBB64-C2	2.7	0.46	36.0	160 to 220
			60		1.0	0.19	22			180 to 240	2.3	0.31	
		AC220	60		1.1	0.23	28	2.5			0.39	42.0	180 to 240
	C230	AC220	50	EAC64-C230	1.0	0.24	25	180 to 240	EBB64-C230	2.5	0.42	36.0	180 to 240
			60		0.91	0.17	22			200 to 260	2.1	0.29	
		AC230	60		1.0	0.21	28	2.3			0.36	42.0	200 to 260
DC with Built-in Rectifier	E1	AC100	50/60	EAC64-E1-1A	0.31		27	90 to 110	EBB64-E1	0.40		34.0	90 to 110
			AC110		0.26		25			100 to 125	0.33		
	E115	AC115	50/60	EAC64-E115-1A	0.27		27	100 to 125	EBB64-E115		0.34		34.0
			AC200		50/60	EAC64-E2-1A	0.15			26	180 to 220	EBB64-E2	0.22
	E230	AC230	50/60	EAC64-E230-1A	0.12		24	200 to 250	EBB64-E230	0.16			30.0
			AC230		50/60	0.13				27	0.17		33.0
DC	D1	DC12	☒	EAC64-D1-1A	2.2		26	10.8 to 13.2	EBB64-D1	2.6		31.0	10.8 to 13.2
	D2	DC24	☒	EAC64-D2-1A	1.1		26	21.6 to 26.4	EBB64-D2	1.5		36.0	21.6 to 26.4

Understanding Model Numbers

SA - G 01 - A 3 X - * * - C2 - 31

Design number
E31: 01 size; 10 - 24 mounting bolt
E21: 03 size; 1/4 - 20 mounting bolt

Power supply
C: AC (50/60Hz) C1=AC100V C115=AC110V C2=AC200V C230=AC220V
D: DC D1=DC12V D2=DC24V
E: AC (Built-in rectifier; 50/60Hz) E1=AC100V E115=AC115V E2=AC200V E230=AC230V

With indicator light

Auxiliary symbol (Can be combined in alphabetic sequence.)
F: Shockless type (Available with power supply D*, E)
G: Surgeless type (Available with power supply C*, D*)
N: With manual push-button
Q: Quick return type (Available with power supply E*)

Transition Flow Path (Specify for A2X, H2X, E2X, A3X, H3X, E3X, A3Z, H3Z, E3Z, C7Y only.)

X	Y	Z
Closed	Semi-open	Open

Center position

0	1	2	3	4	5
6	7	8	9	1S	6S

Note 1: P=Pressure port; A and B=Connection port to cylinder, etc.; T=Connection port to tank

Operation Method

A	H	C	E
Spring Offset	Spring Center	Spring Center	Detent

Nominal diameter
01 size (D03)
03 size (D05)

Mounting method
G: Cascade mounting

Wet type solenoid operated directional control valve

Options

(Auxiliary Symbol Explanations)

G Screw Adapter
(Auxiliary Symbol: J)

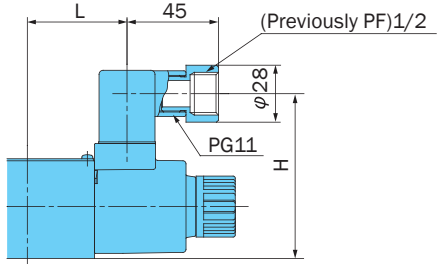

Model No.	L	H
SA-G01	49	81
SA-G03	60.5	100.5

With manual push-button
(Auxiliary Symbol: N)

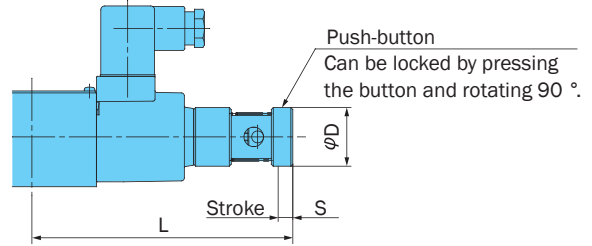

Part No.		L	S	D
EDB14-D-1A	AC Solenoid	133.5	7.5	30
	DC Solenoid	140.5		
ECB14-A	AC Solenoid	155.5	9.5	35
	DC Solenoid	173.5		

Other Options

Note: For information about the shockless and surgeless options, see page D-7.

Installation Dimension Drawings

AC Solenoid

SA-G01-A**-*-C*-E31

SA-G01-H**-*-C*-E31

Note: SA-G01-H**-R**-E31
The solenoid is on the opposite side of that shown for SOLa in the illustrations shown here.

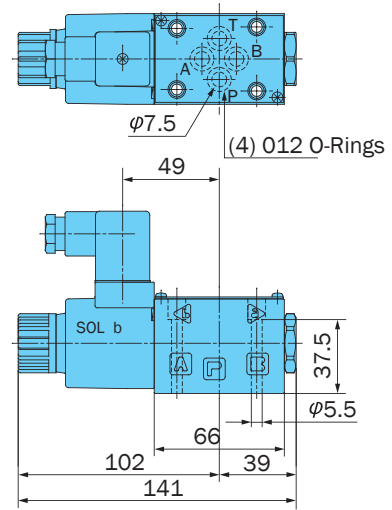
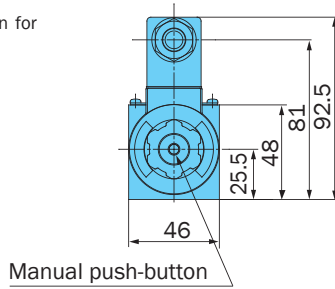

SA-G01-C**-R-C*-E31

SA-G01-E**-R-C*-E31

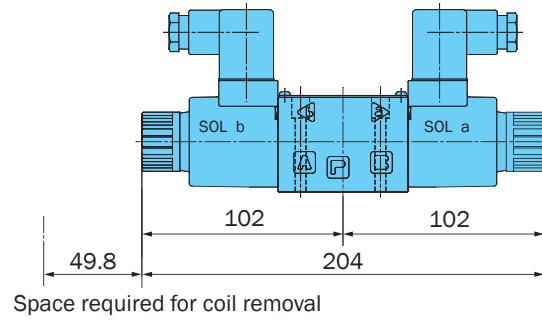

DC Solenoid and Rectifier

SA-G01-A**-D*/E*-E31

SA-G01-H**-D*/E*-E31

SA-G01-C**-D*/E*-E31

SA-G01-E**-D*/E*-E31

Note: 1.SA-G01-H**-D*/E*-E31
The solenoid is on the opposite side of that shown for SOLa in the illustrations shown here.
2.SA-G01-**-E*-E31
Dimension 1 is 96.
Dimension 2 is 73.

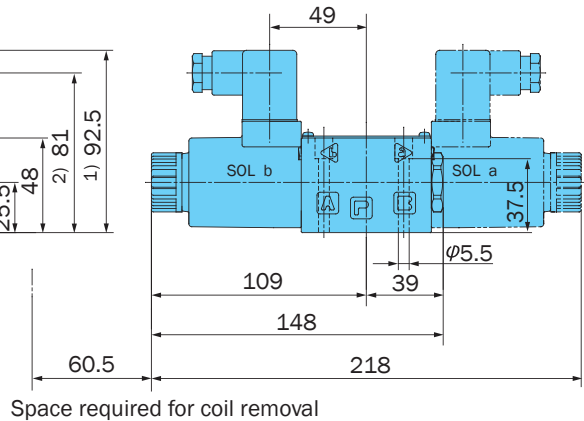
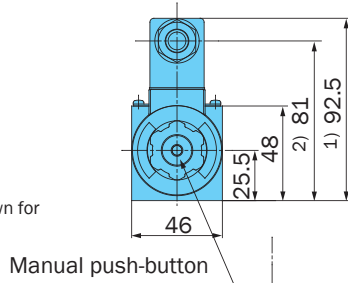

For sub plate SA-G01

Model No.	E	Weight lbs
MSA-01X-E10	1/4	2.6
MSA-01Y-E10	3/8	2.6

Gasket Surface Dimensions
(ISO 4401-03-02-0-94
JIS B 8355 D-03-02-0-94)

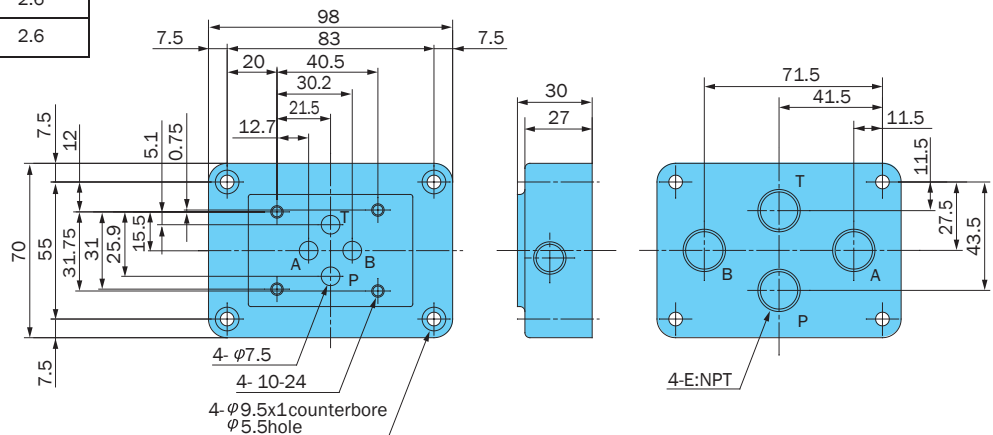

Installation Dimension Drawings

AC Solenoid

SA-G03-A***-C*-E21

SA-G03-H***-C*-E21

Note: SA-G03-H***-C*-E21

The solenoid is on the opposite side of that shown for SOLa in the illustrations shown here.

	SA-G03-***-C*-E21	SA-G03-***-H*-E21
ϕD	$\phi 6.8$	$\phi 8.5$
L	60.5	58

SA-G03-C***-C*-E21

SA-G03-E***-C*-E21

DC Solenoid and Rectifier

SA-G03-A***-D*/E*-E21

SA-G03-H***-D*/E*-E21

SA-G03-C***-D*/E*-E21

SA-G03-E***-D*/E*-E21

Note: 1.SA-G03-H***-D*/E21

The solenoid is on the opposite side of that shown for SOLa in the illustrations shown here.

- SA-G03-***-E*-E21
Dimension 1 is 115.5.
Dimension 2 is 92.5.

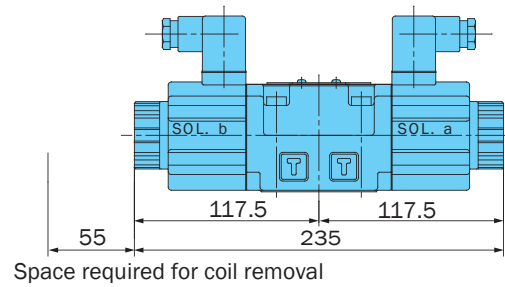
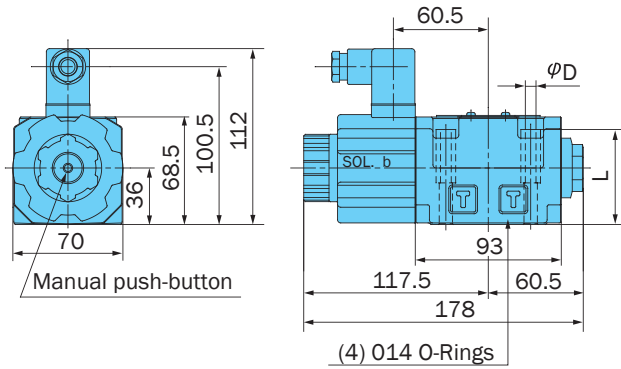
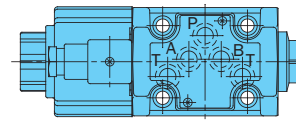
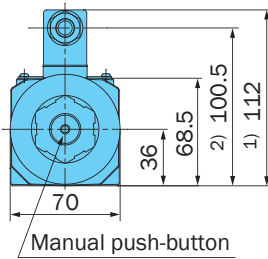

Space required for coil removal

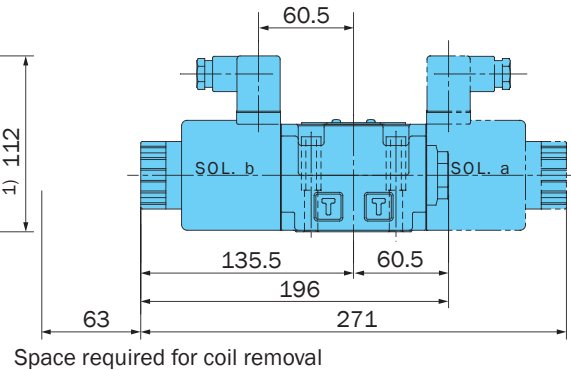

Space required for coil removal

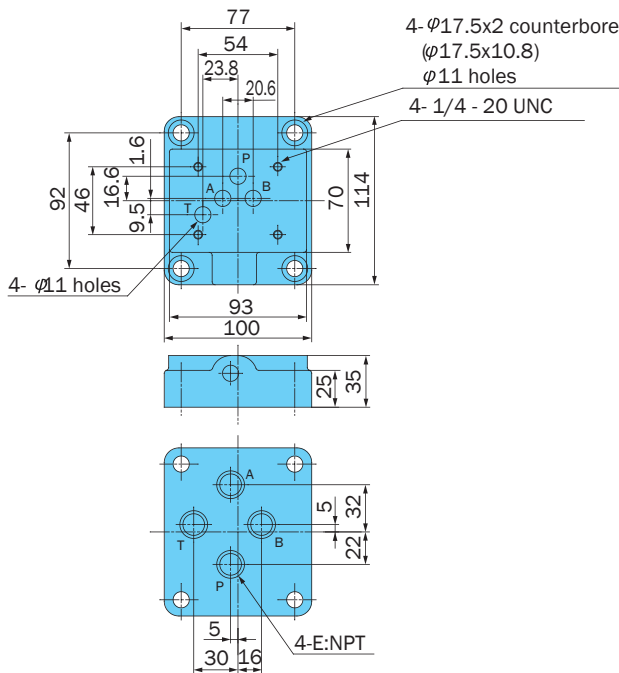



For sub plate SA-G03

Mounting bolt	Model No.	E	Weight lbs
1/4 - 20 x 2 3/4	MSA-03-E10	3/8	5.0
	MSA-03X-E10	1/2	

Gasket surface dimensions
(ISO 4401-05-04-0-94
JIS B 8355 D-05-04-0-94)

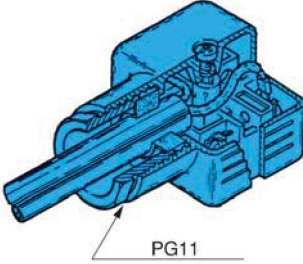
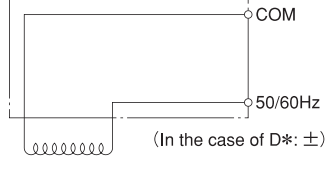
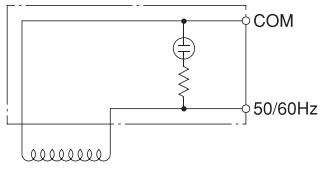
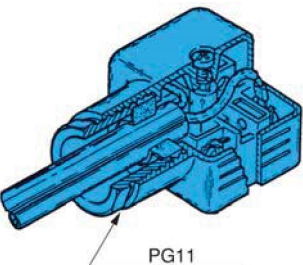
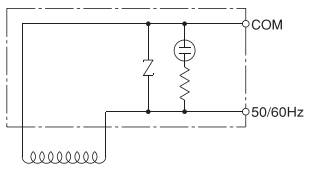
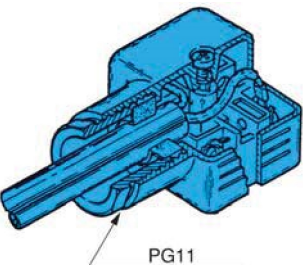
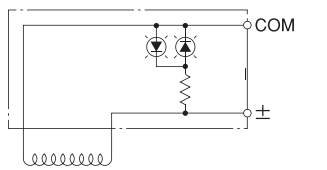
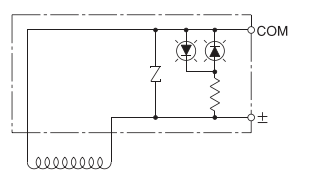
• Connectors

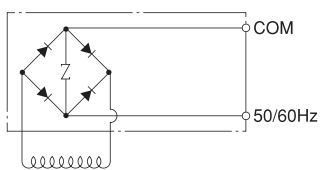
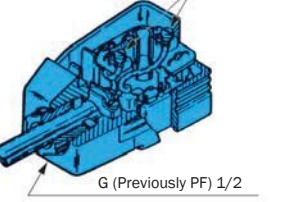
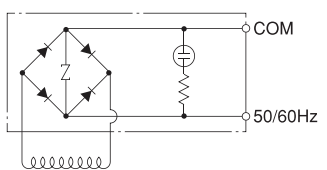
Model No.	Wiring	Electrical Circuit Diagram
SA- G01-***C* 31 G03-***D* E21 (EA41-1A)	 <p>Connect the power supply to terminals No.1 and No. 2. The ⊕ terminal is ground. Use this terminal as required.</p>	 <p>(In the case of D*: ±)</p>
SA- G01-***R-C* 31 G03 E21 (EA41-R*-1C)		
SA- G01-***GR-C* 31 G03 E21 (EA41-GRC*-1C)	 <p>Connect the power supply to terminals No.1 and No. 2. The ⊕ terminal is ground. Use this terminal as required.</p>	
SA- G01-***R-D* 31 G03 E21 (EA41-DR*-1C)		
SA- G01-***GR-D* 31 G03 E21 (EA41-GRD*-1C)		
SA- G01-***E* 31 G03 E21 (EA42-1B)		
SA- G01-***R-E* 31 G03 E21 (EA42-R*-1B)		

Symbols in parentheses indicate connector configuration.

- Note:
- 1.Asterisks in the connector configuration and power supply symbols are fillers for the voltage symbol (1 or 2).
 - 2.The connector cord diameter is $\varnothing 8$ to 10. Anything outside this range causes water tightness to be lost.
 - 3.The orientation of the connectors can be changed in 90° increments by changing the terminal block.
 - 4.The cover cannot be removed unless the installation screws are removed.
 - 5.When J is specified for the auxiliary symbol, a G screw conversion adapter is attached to the connector, and the wiring port is a G (previously PF) 1/2 screw (standard: PG11). EA42 and EA42-R* also have a G (previously PF) wiring port.
 - 6.Use M3 for round type and Y type solderless terminals.
 - 7.Tighten the M3 screws that secure connectors and terminals to a torque of 42 to 70 in lbs.
 - 8.An EA-41-1A or EA41-R*-1C connector is used in the case of power supply type E* with Quick Return type Q.

Performance Curves

Hydraulic Operating Fluid Viscosity 32 centistokes

Pressure Loss Characteristics

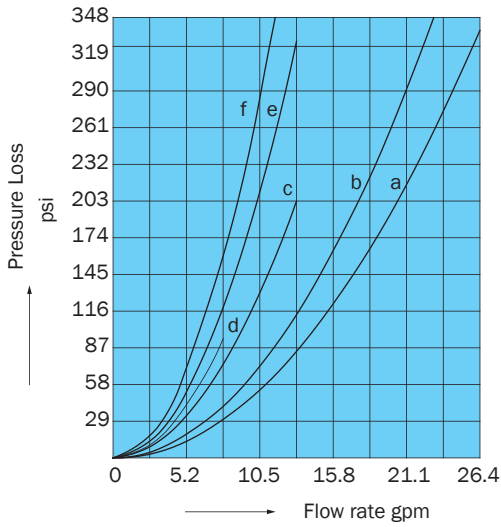

Pump Type	Flow Path	P/ A	P/ B	A/ T	B/ T	P/ T
SA-G01	A2X, H2X, E2X	d	d	--	--	--
	A3X, H3X	b	b	b	b	--
	E3X	b	b	b	b	--
	A3Z, H3Z, E3Z	a	a	a	a	--
	A4, H4, C4	a	a	a	a	a
	A5, H5, C5, C6S	b	b	b	b	--
	C1, C1S	b	b	a	b	--
	C2	a	b	b	b	--
	C6	b	b	a	a	--
	C7Y	f	f	e	e	c
	C8	a	f	b	e	c
C9	a	a	b	b	--	

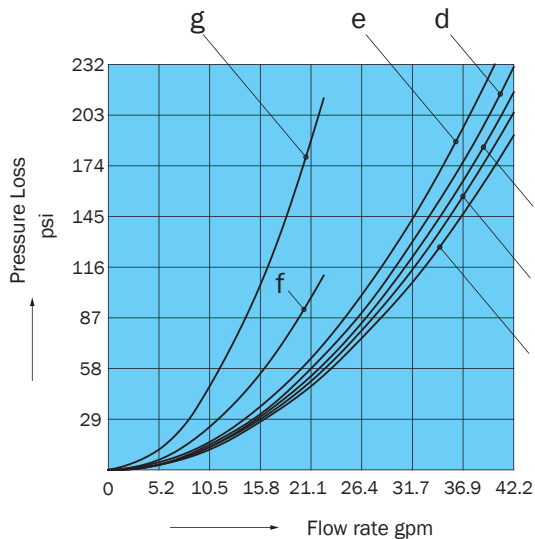

Pump Type	Flow Path	P/ A	P/ B	A/ T	B/ T	P/ T
SA-G03	A2X, H2X, E2X	e	e	--	--	--
	A5	--	c	c	--	--
	H5	c	--	--	c	--
	A3X, H3X, E3X	c	c	d	d	--
	A3Z, H3Z	a	a	d	d	--
	E3Z	b	b	a	a	--
	C1	c	c	a	c	--
	C2	a	c	c	c	--
	A4, H4, C4	a	a	a	a	a
	C5, C1S, C6S	c	c	c	c	--
	C6	c	c	a	a	--
	C7Y	g	g	g	g	f
	C8	a	g	a	g	f
C9	a	a	c	c	--	

Switching Response Time

Model No.	Response Time (sec)		Measurement Conditions
	Solenoid ON	Spring Return	
SA-G01-**-*(GR)-C*-E31	0.02 to 0.03	0.02 to 0.03	} 2030 psi 7.9 gpm
SA-G01-**-*(GR)-D*-E31	0.03 to 0.04	0.02 to 0.04	
SA-G01-**-*(R)-E*-E31	0.03 to 0.04	0.07 to 0.10	
SA-G01-**-*(GR)-D*-E31	0.07 to 0.10	0.04 to 0.07	
SA-G01-**-*(R)-E*-E31	0.07 to 0.10	0.10 to 0.15	
SA-G03-**-*(GR)-C*-E21	0.02 to 0.03	0.02 to 0.03	} 2030 psi 18.4 gpm
SA-G03-**-*(GR)-D*-E21	0.06 to 0.09	0.03 to 0.05	
SA-G03-**-*(R)-E*-E21	0.07 to 0.10	0.10 to 0.15	
SA-G03-**-*(GR)-D*-E21	0.13 to 0.15	0.08 to 0.15	
SA-G03-**-*(R)-E*-E21	0.10 to 0.15	0.15 to 0.20	

Note: 1. The switching response time changes slightly with operating conditions (pressure, flow rate, viscosity, etc.)

• Pressure - Flow Volume Allowable Value

Size	Standard Form, with AC, DC solenoid		
	SA-G01-**-R**-31		
Operation Example Operation Symbol			
A2X, H2X	-	K	K
E2X	-	J	J
A3X, H3X	B	K	K
E3X	A	J	J
A3Z, H3Z	D	D	D
E3Z	D	D	D
A5	A	-	I
H5	A	I	-
C1, C6	Note1) C(E)	I	I
C1S, C5, C6S	A	I	I
C2, C9	A	K	K
A4	F	F	F
H4	F	F	F
C4	F	F	F
C7Y, C8	Note2) G(H)	K	K

Size	Shockless Type, with DC solenoid		
	SA-G01-**-FR**-31		
Operation Example Operation Symbol			
A2X, H2X	-	P	-
E2X	-	O	P
A3X, H3X	L	P	P
E3X	L	O	L
A3Z, H3Z	L	L	L
E3Z	L	L	P
A5	L	-	
H5	L	P	
C1, C6	M	P	
C1S, C2, C5, C6S, C9	L	P	
A4, H4	L	L	
C4	L	L	
C7Y, C8	N	P	

Note: 1. Letter in parentheses is for AC solenoid.
 2. Letter in parentheses is for solenoid with built-in rectifier, but without Quick Return, and for DC solenoid with surge voltage absorbing diode on the electrical circuit.

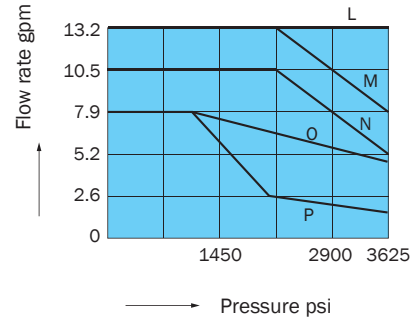
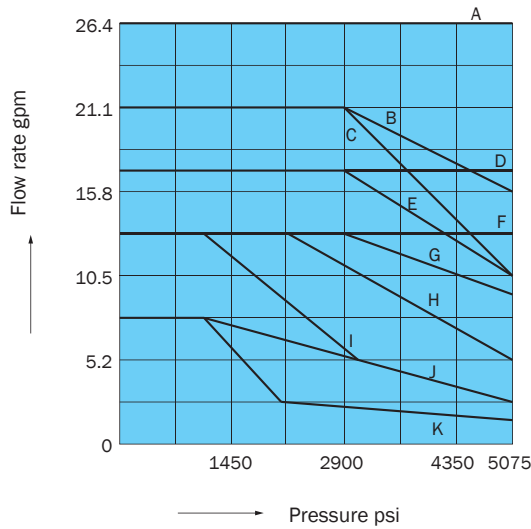

• Pressure - Flow Volume Allowable Value

Model No.	Standard Form, with AC, DC solenoid			Standard Form, with DC solenoid		
	SA-G03-**-C*-E21			SA-G03-**-**-E21		
Operation Example						
Operation Symbol						
A2X	--	F	E	--	G	H
H2X	--	E	F	--	H	G
E2X	--	C	C	--	D	D
A3X	A	E	E	A	F	H
H3X	A	E	E	A	H	F
A3Z	A	A	C	A	D	D
H3Z	A	C	A	A	D	D
E3X, E3Z	A	C	C	A	D	D
A5	A	--	D	A	--	G
H5	A	D	--	A	G	--
C1S, C5, C6S	A	D	D	A	G	G
C1, C6	A	D	D	B	G	G
C2	A	G	D	A	I	G
A4, H4, C4	A	A	A	A	A	A
C9	A	G	G	A	I	I
C7Y, C8	B	B	B	Note1) C(E)	C(E)	C(E)
Model No.	Shockless Type, with DC solenoid					
	SA-G03-**-F**-E21					
Operation Example						
Operation Symbol						
A2X	☒	E	F			
H2X	☒	F	E			
E2X	☒	C	C			
A3X	A	D	F			
H3X	A	F	D			
A3Z	A	C	C			
H3Z	A	C	C			
E3X, E3Z	A	C	C			
A5	A	--	E			
H5	A	E	--			
C1, C1S, C5, C6, C6S	A	E	E			
C2	A	G	E			
A4, H4, C4	A	A	A			
C9	A	G	G			
C7Y, C8	Note 1: B(H)	B(H)	B(H)			

- Note: 1. Letter in parentheses is for solenoid with built-in rectifier (E*), but without Quick Return, and for DC solenoid (D*) with surge voltage absorbing diode on the electrical circuit.
 2. There is no shockless type for the AC solenoid (C*), so use a solenoid with built-in rectifier (E*) when shockless operation is required with an AC power supply.
 3. The maximum flow rate is the allowable value of each port.

Cross-sectional Drawing

SA-G01-A**-C*-31

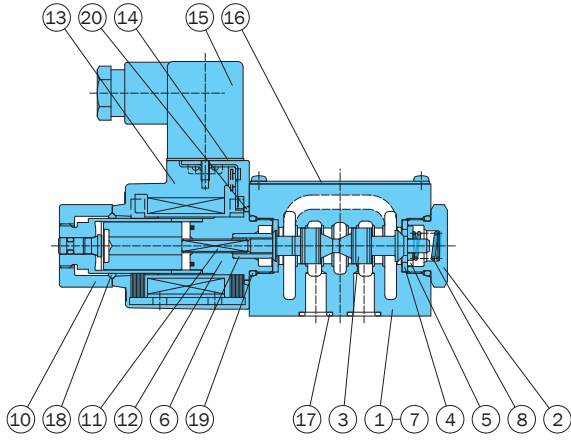

SA-G01-C**-C*-31

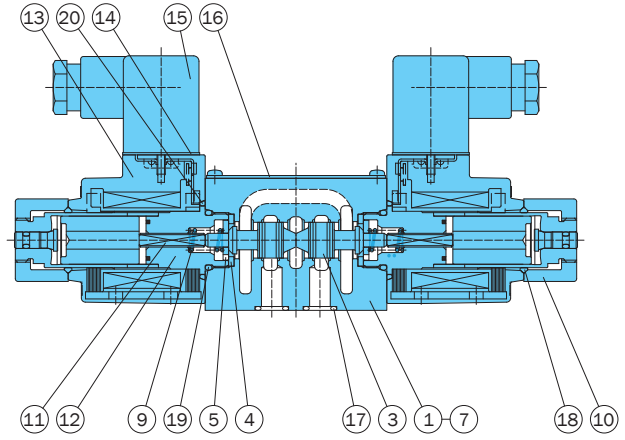

SA-G01-A**-D/E*-31

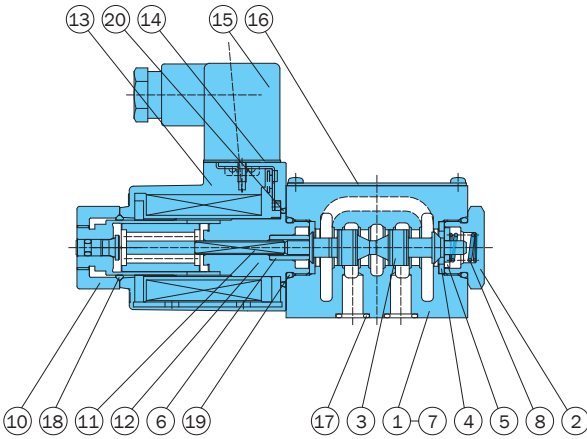

SA-G01-C**-D/E*-31

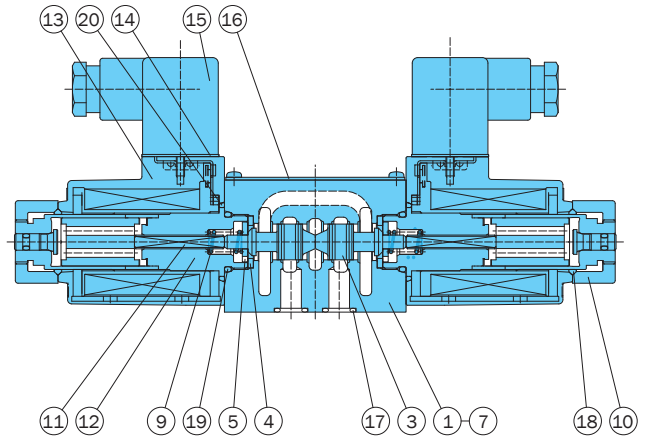

List of Sealing Parts

Part No.	Part Name	Part Number	Qty	
			Single Solenoid	Double Solenoid
17	O-ring	AS568-012(Hs90)	4	4
18	O-ring	1A-P20	1	2
19	O-ring	1B-P18	2	2
20	O-ring	S-25	1	2

Note: 1A and 1B are JIS Standard B 2401, while AS568 is SAE standard.

Part No.	Part Name	Part No.	Part Name
1	Body	11	Rod
2	Plug	12	Solenoid guide
3	Spool	13	Solenoid coil
4	Retainer A	14	Packing
5	Retainer B	15	Connector
6	Spring pin	16	Nameplate
7	Spacer	17	O-ring
8	Spring A	18	O-ring
9	Spring C	19	O-ring
10	Nut	20	O-ring

Seal Kit Number

Single Solenoid	Double Solenoid
EDCS-A	EDCS-C

Cross-sectional Drawing

SA-G03-A**-C*-E21

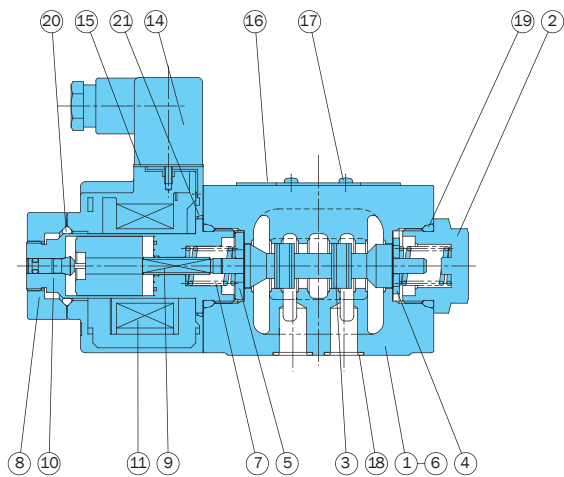

SA-G03-C**-C*-E21

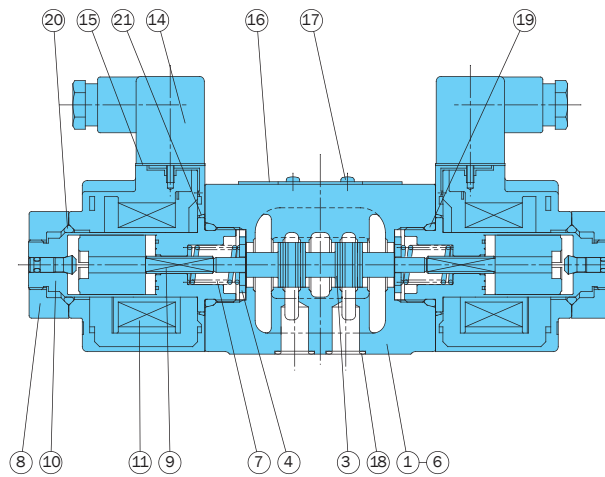

SA-G03-A**-D/E*-E21

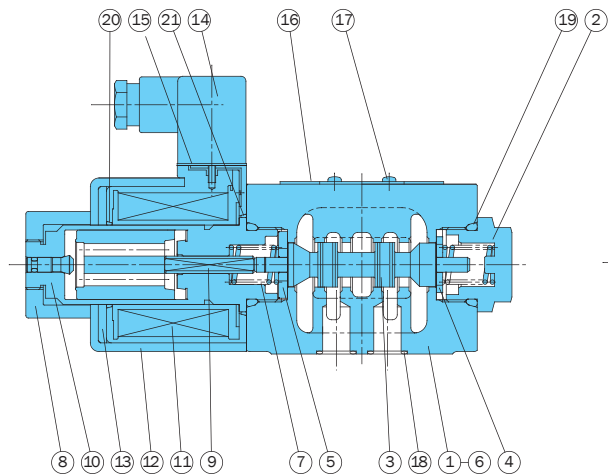

SA-G03-C**-D/E*-E21

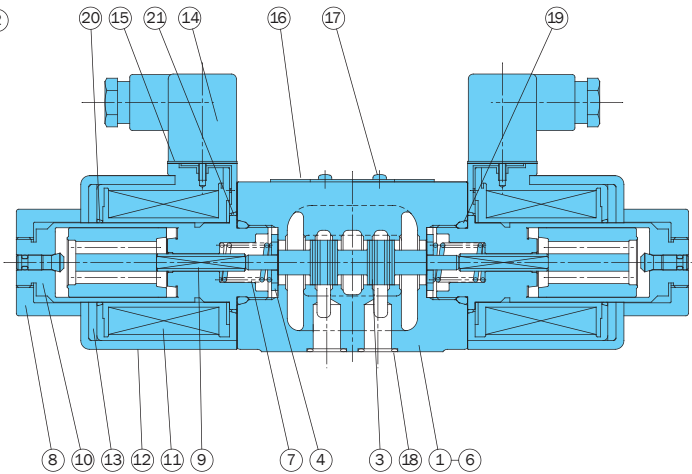

List of Sealing Parts

Part No.	Part Name	Type/Part Number		Q'ty	
		AC SOL.	DC SOL.	Single Solenoid	Double Solenoid
18	O-ring	AS568-014(Hs90)		5	5
19	O-ring	1B-P28		2	2
20	O-ring	1A-P26	AS568-026	1	2
21	O-ring	AS568-029		1	2

Note: O-ring 1A/B-** refers to JIS B2401-1A/B.

Part No.	Part Name	Part No.	Part Name
1	Body	11	Solenoid coil
2	Plug	12	Coil case
3	Spool	13	Coil yoke
4	Retainer	14	Connector
5	Retainer B	15	Connector packing
6	Spacer	16	Nameplate
7	Spring	17	Screw
8	Nut	18	O-ring
9	Rod	19	O-ring
10	Solenoid guide	20	O-ring
		21	O-ring

Seal Kit Number

AC SOL.		DC SOL.	
Single Solenoid	Double Solenoid	Single Solenoid	Double Solenoid
ECBS-AA	ECBS-CA	ECBS-AD	ECBS-CD