

VDC Series High Pressure Type Variable Volume Vane Pump

7.9 to 31.7 gpm
2000 psi

Features

Highly efficient and stable high-pressure operation

Innovative pressure control and pressure balance mechanisms combine with an original 3-point ring support system dramatically improves high-pressure operation. The result is outstanding performance at high pressures up to 2000 psi.

Low vibration and noise

A number of innovative new mechanisms are adopted to minimize vibration and noise. In particular, a 3-point support system is used for the control piston and bias piston to increase ring

stability. This minimizes ring vibration and delivers quiet operation.

Outstanding response, high-precision operation

An innovative new ring stopper eliminates excessive ring displacement and improves response. The result is high precision operation at all times, including during starts, stops, and load changes.

Precise characteristics for a stable discharge rate

A revolutionary new pressure compensator type pressure control mechanism

ensures a highly stable fixed discharge rate, even in the high pressure range.

High efficiency operation with minimal power loss

New mechanical innovations minimize power loss, especially at full cutoff.

Simplified maintenance and handling

Pressure adjusting and discharge rate adjusting mechanisms are located on the same side of the pump for simplified maintenance and handling.

Specifications

Single Pump

Model No.		Capacity in ³ /rev	No-load Discharge Rate gpm		Pressure Adjustment Range kgf/cm (psi)	Allowable Peak Pressure kgf/cm (psi)	Revolution Speed min ⁻¹		Weight lbs
Foot Mounting	Flange Mounting		1500min ⁻¹	1800min ⁻¹			Min.	Max.	
VDC-1A-1A2-*20 VDC-1A-1A3-*20 VDC-1A-1A4-*20 VDC-1A-1A5-*20	VDC-1B-1A2-*20/35 VDC-1B-1A3-*20/35 VDC-1B-1A4-*20/35 VDC-1B-1A5-*20/35	1.0	6.6	7.9	15.3 to 35.7 (217 to 507) 20.4 to 71.4 (290 to 1000) 51 to 107 (725 to 1500) 71.4 to 143 (1000 to 2000)	143 (2000)	800	1800	21
						214 (3000)			
VDC-1A-2A2-*20 VDC-1A-2A3-*20	VDC-1B-2A2-*20/35 VDC-1B-2A3-*20/35	1.3	8.7	10.5	15.3 to 35.7 (217 to 507) 20.4 to 71.4 (290 to 1000)	143 (2000)	800	1800	21
VDC-2A-1A2-*20 VDC-2A-1A3-*20 VDC-2A-1A4-*20 VDC-2A-1A5-*20	VDC-2B-1A2-*20/35 VDC-2B-1A3-*20/35 VDC-2B-1A4-*20/35 VDC-2B-1A5-*20/35	1.8	11.8	14.2	15.3 to 35.7 (217 to 507) 20.4 to 71.4 (290 to 1000) 51 to 107 (725 to 1500) 71.4 to 143 (1000 to 2000)	143 (2000)	800	1800	55
						214 (3000)			
VDC-2A-2A2-*20 VDC-2A-2A3-*20	VDC-2B-2A2-*20/35 VDC-2B-2A3-*20/35	2.3	15.3	18.4	15.3 to 35.7 (217 to 507) 20.4 to 71.4 (290 to 1000)	143 (2000)	800	1800	55
VDC-3A-1A2-*20 VDC-3A-1A3-*20 VDC-3A-1A4-*20 VDC-3A-1A5-*20	VDC-3B-1A2-*20 VDC-3B-1A3-*20 VDC-3B-1A4-*20 VDC-3B-1A5-*20	4.0	26.4	31.7	15.3 to 35.7 (217 to 507) 20.4 to 71.4 (290 to 1000) 51 to 107 (725 to 1500) 71.4 to 143 (1000 to 2000)	143 (2000)	800	1800	103
						214 (3000)			

Double Pump

Model No.	Vent Side			Shaft Side			Revolution Speed min ⁻¹		Weight lbs
	Discharge Rate gpm		Pressure Adjustment Range kgf/cm (psi)	Discharge Rate gpm		Pressure Adjustment Range kgf/cm (psi)	Min.	Max.	
	1800min ⁻¹	1500min ⁻¹		1800min ⁻¹	1500min ⁻¹				
VDC-11A(B)-2A3-2A*20/35 VDC-11A(B)-2A3-1A*20/35	10.5	8.7	20.4 to 71.4 (290 to 1000)	10.5 7.9	8.7 6.6	20.4 to 71.4 (290 to 1000) 71.4 to 143 (1000 to 2000)	800	1800	Type A 59 Type B 44
VDC-12A(B)-2A3-2A*20/35 VDC-12A(B)-2A3-1A*20/35 VDC-12A(B)-1A5-2A*20/35 VDC-12A(B)-1A5-1A*20/35	10.5 7.9	8.7 6.6	20.4 to 71.4 (290 to 1000) 71.4 to 143 (1000 to 2000)	18.4 14.2 18.4 14.2	15.3 11.8 15.3 11.8	20.4 to 71.4 (290 to 1000) 71.4 to 143 (1000 to 2000) 20.4 to 71.4 (290 to 1000) 71.4 to 143 (1000 to 2000)	800	1800	Type A 92 Type B 77
VDC-22A(B)-2A3-2A*20/35 VDC-22A(B)-2A3-1A*20/35	18.4	15.3	20.4 to 71.4 (290 to 1000)	18.4 17.2	15.3 11.8	20.4 to 71.4 (290 to 1000) 71.4 to 143 (1000 to 2000)	800	1800	Type A 136 Type B 110
VDC-13A(B)-2A3-1A*20 VDC-13A(B)-2A3-1A*20 VDC-13A(B)-1A5-1A*20 VDC-13A(B)-1A5-1A*20	10.5 7.9	8.7 6.6	20.4 to 71.4 (290 to 1000) 71.4 to 143 (1000 to 2000)	31.7	26.4	20.4 to 71.4 (290 to 1000) 71.4 to 143 (1000 to 2000) 20.4 to 71.4 (290 to 1000) 71.4 to 143 (1000 to 2000)	800	1800	Type A 136 Type B 105

Note: 1. VDC-3A, VDC-11A, VDC-12A and VDC-13A are foot mounting types, and come with foot mountings.
2. VDC-1A and VDC-2A are sub plate types. Sub plates are not included.

• Handling

- 1 Rotation Direction The direction of rotation is always clockwise (rightward) when viewed from the shaft side.
- 2 Drain Drain piping must be direct piping up to a point that is below the tank fluid level, and piping should comply with the conditions shown in the table below to ensure that back pressure due to pipe resistance does not exceed 14 psi. When using a pump that has drain ports at two locations, use the drain port that is higher after the pump is installed. In the case of a double pump, run separate pipes from both the shaft side and the head side drains directly connect to the tank, so the drain pipe is below the surface of the oil.
- 3 Discharge Volume Adjustment

Model No. Item	VDC-1	VDC-2	VDC-3
Pipe Joint Size	At least 1/4"	At least 1/4"	At least 3/8"
Pipe I.D.	At least .29	At least .29	At least .37
Pipe Length	1m or less	1m or less	1m or less

The discharge flow rate is decreased by clockwise (rightward) rotation of the discharge rate adjusting screw, and increased by counterclockwise (leftward) rotation.

Loosen the lock nut before making adjustments. After adjustment is complete, re-tighten the lock nut. The graph below provides general guidelines for the relationship between the rotation angle of the flow rate adjusting screw and the no-load discharge rate.

$$Q: \text{Flow rate gpm} = \frac{\text{in}^3 \times \text{rpm}}{231}$$

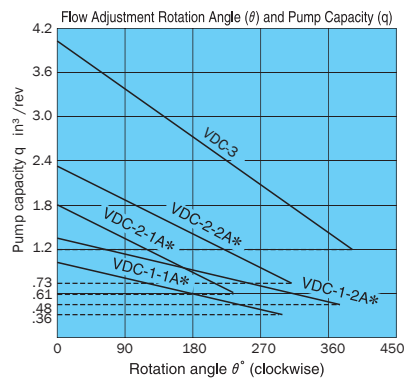

Factory Default Pressure Settings kgf/cm ² (psi)
2: 35.7 (507)
3: 30.6 (435)
4: 5.1 (725)
5: 71.4 (1000)

- 4 Pressure Adjustment Pressure is increased by clockwise (rightward) rotation of the discharge rate adjusting screw, and decreased by counterclockwise (leftward) rotation. Loosen the lock nut before making adjustments. After adjustment is complete, re-tighten the lock nut.
- 5 Factory Default P-Q Settings (Standard Model)
 - Flow Rate Setting = Maximum flow rate for model as indicated in the catalog
 - Pressure Setting = Pressure shown in table below
- 6 Thrust Screw and Stopper The thrust screw and stopper are precision adjusted at the factory during assembly. Never touch them. See callouts 15/43 and 15/38 in the VDC-1A and 2A/3A cross-section diagrams on pages B-33 and B-34.
- 7 An unload circuit is required when the motor is started under condition WYE Delta. Contact your agent about the unload circuit.
- 8 Initial Operation Before operating the pump for the first time, put the pump discharge side into the no-load state and then repeatedly start and stop the motor to bleed all air from inside the pump and the suction piping. After confirming that the pump is discharging oil, continue the no-load operation for at least 10 minutes to discharge all the air from the circuit. Provide an air bleed valve in circuits where it is difficult to bleed air before startup.
- 9 Sub Plate Use the table below for to specify a sub plate type when one is required.

- 10 Foot Mounting For a double pump with VDC-3 foot mounting, the foot mounting kit and pump are sold as a set. When only the mounting feet are required, pump mounting bolts, washers and other parts are sold together as the Foot Mounting Kit. See page B-36 for detailed dimensions.
- 11 For the hydraulic operating fluid, use type ISO VG32 or equivalent (viscosity index of at least 90) for pressures of 1000 psi or lower, and type ISO VG68 or equivalent (viscosity index of at least 90) for pressures greater than 1000 psi.
- 12 The operating temperature range is 59 to 140 °F. When the oil temperature at startup is 59 °F or less, perform a warm-up operation at low pressure until the oil temperature reaches 59 °F. Use the pump in an area where the temperature is within the range of 32 to 140 °F.
- 13 Suction pressure is 4.35 psi, and the suction port flow rate should be no greater than 6 ft/sec.
- 14 Avoid pulley, gear, and other drive systems that impart a radial or thrust load on the end of the pump shaft. Mount the pump so its pump shaft is oriented horizontally.
- 15 Provide a suction strainer with a filtering grade of about 100µm (150 mesh). For the return line to the tank, use a 10µm line filter.
- 16 Manage hydraulic operating fluid so contamination is maintained at class NAS10 or lower. Take care to avoid contamination with water and other foreign matter, and watch out for discoloration. Whitish fluid indicates that water has contaminated the fluid, and brownish fluid indicates the fluid is dirty.
- 17 Contact your agent about using water- and glycol-based hydraulic operating fluids.
- 18 At startup, repeat the inching operation (start-stop) to bleed air from the pump and pipes.

(Continued on following page)

Sub Plate Number

Pump Model No.	Sub Plate Number	Motor (hp)
VDC-1A-1A*-20	MVD-1-115-10	1 - 2
	MVD-1-135-10	3 - 5
VDC-1A-2A*-20	MVD-1-115Y-10	1 - 2
	MVD-1-135Y-10	3 - 5
VDC-2A-*A*-20	MVD-2-135-10	3 - 5
	MVD-2-160-10	7
VDC-2A-2A*-20	MVD-2-160Z-10	7

Note: See pages B-17 and B-18 for detailed dimensions.

Note:

The values indicated above are at maximum pump discharge volume with the flow volume adjusting screw at the 0° position. The broken line shows the flow volume adjustment range lower limit value.

- 19 Equip an air bleed valve in circuits where it is difficult to bleed air before startup. See page C-13 for more information.
- 20 To ensure proper lubrication of the pump's rubbing surfaces, supply oil to the interior of the pump before starting operation.

- 21 When centering the pump shaft, eccentricity with the motor shaft should be no greater than 0.001 in. Use a pump mounting base of sufficient rigidity. The angle error should be no greater than 1°.

Understanding Model Numbers

Single Pump

VDC -- 2 A -- 1 A 2 * 20

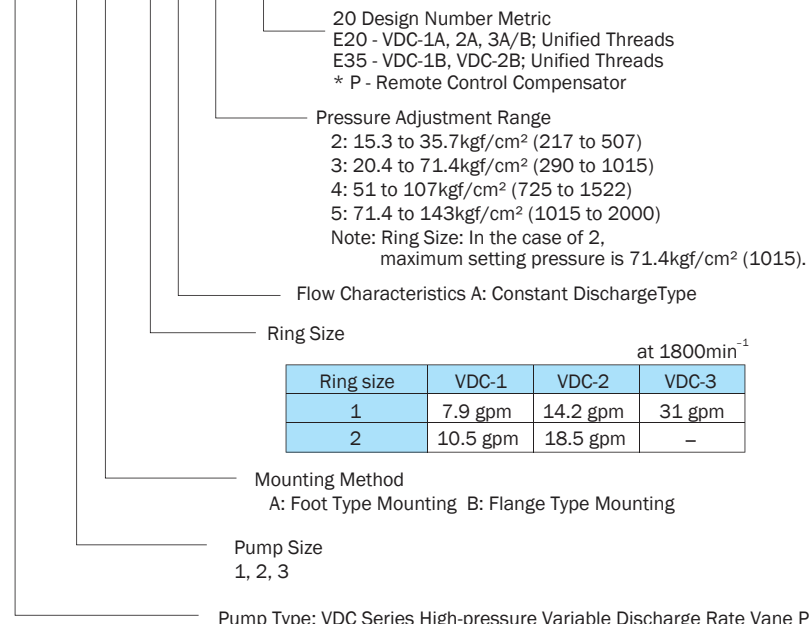

The ZR-T02-*5895* is the recommended remote control valve. Provide piping to the remote control valve at a pipe volume of 9 cu in or less.

Double Pump

VDC -- 1 2 A -- 1 A 5 -- 2 A 3 -- 20

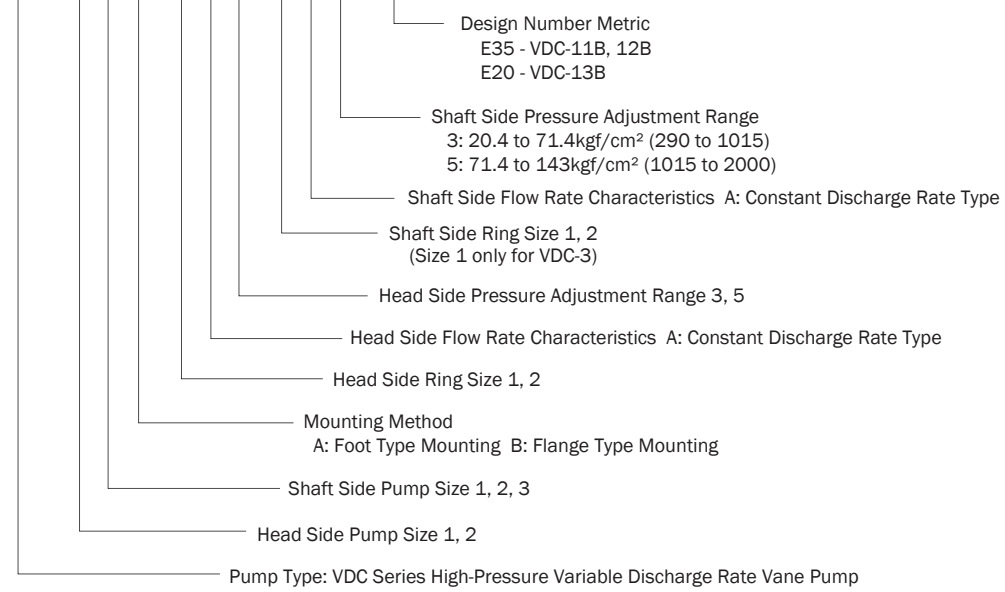

Installation Dimension Drawings

Single Pump
VDC-1A-*A*-20

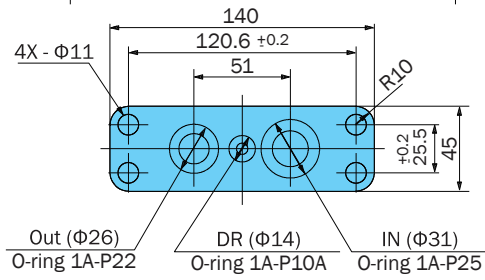
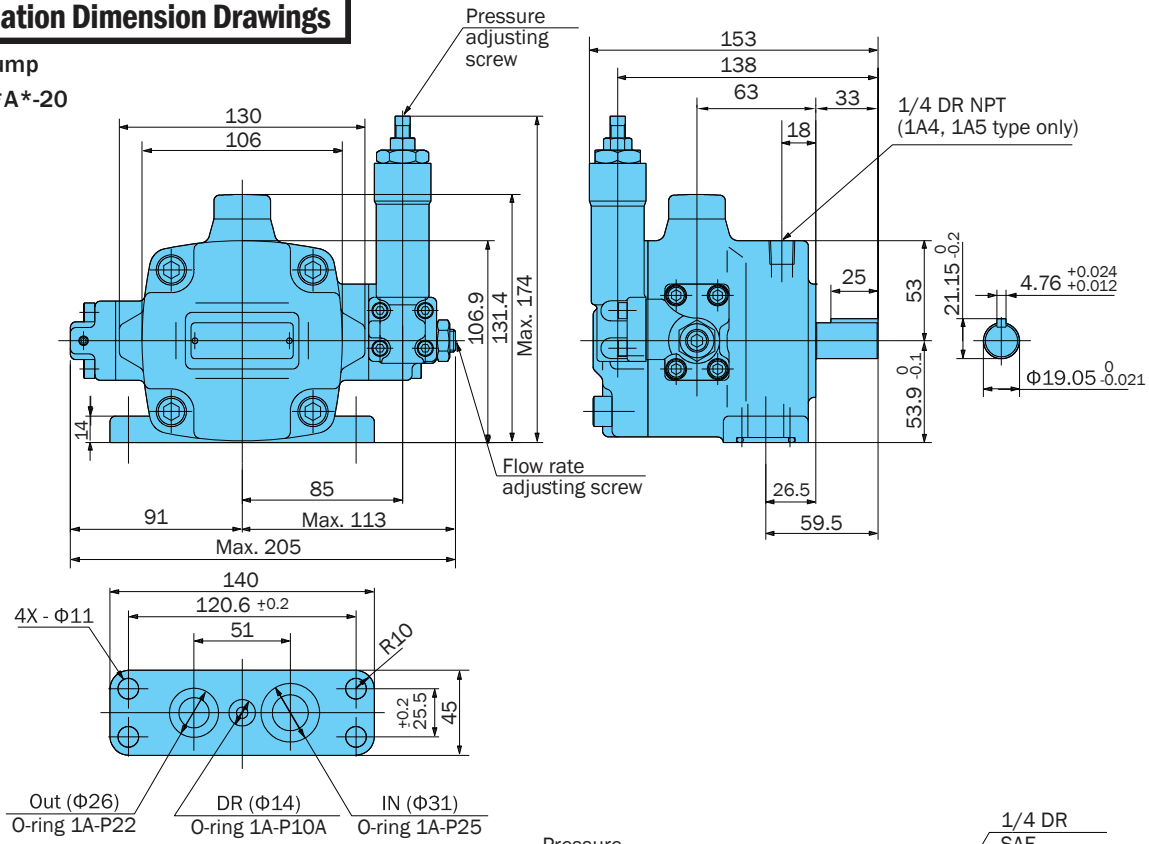

VDC-1B-*A*-E35
SAE A Mount

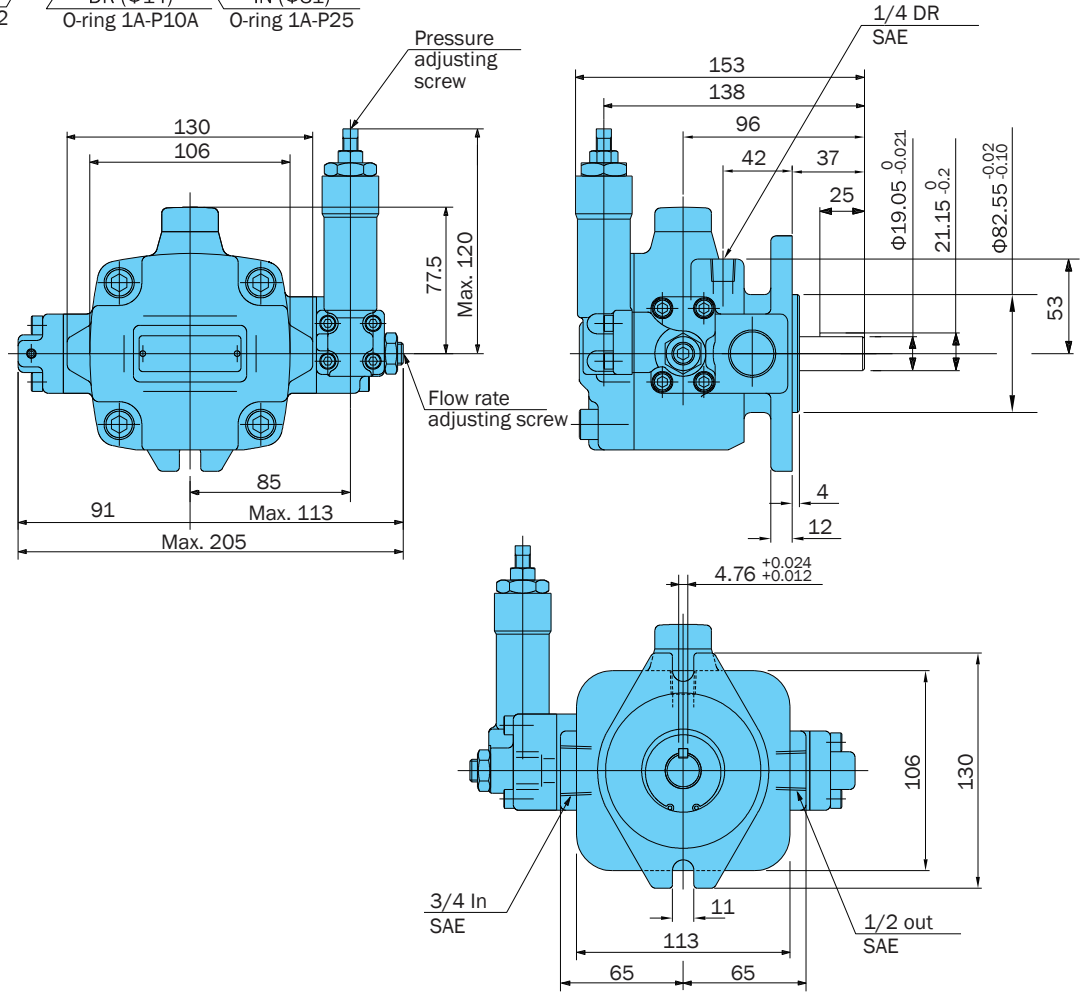

VDC-2A-*A*-20

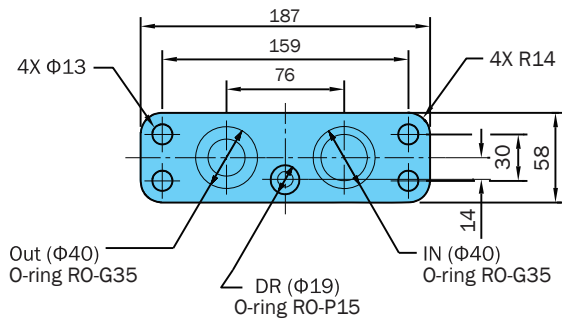
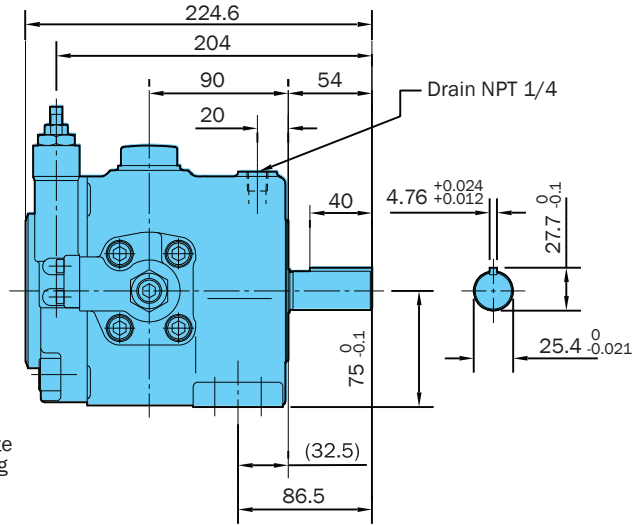
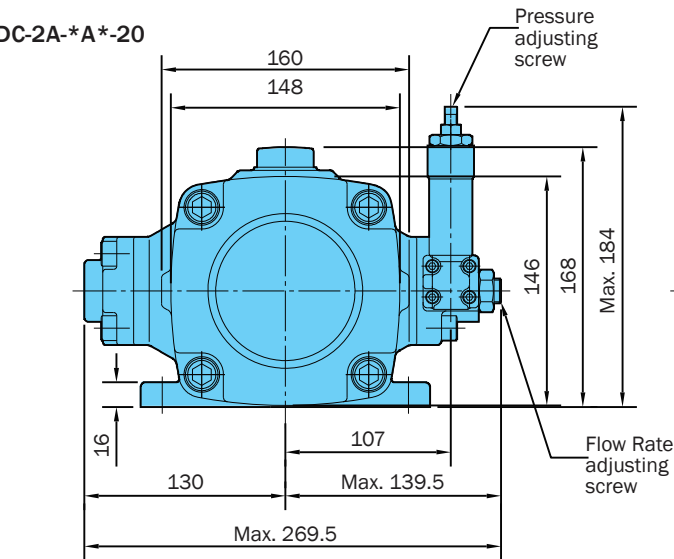

VDC-2B-*A*-20
SAE B Mount

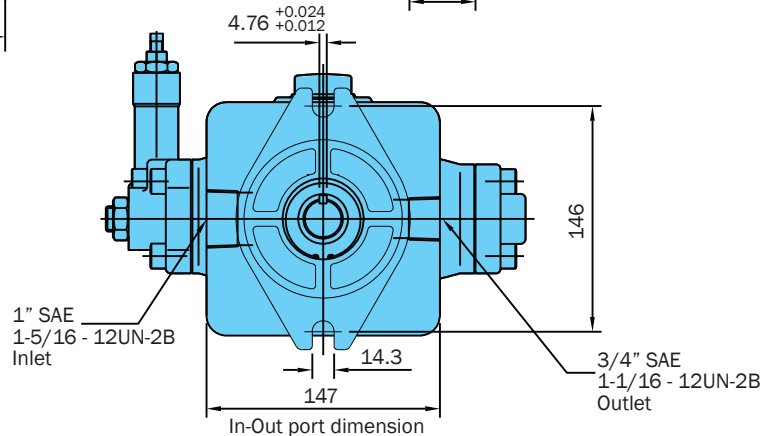
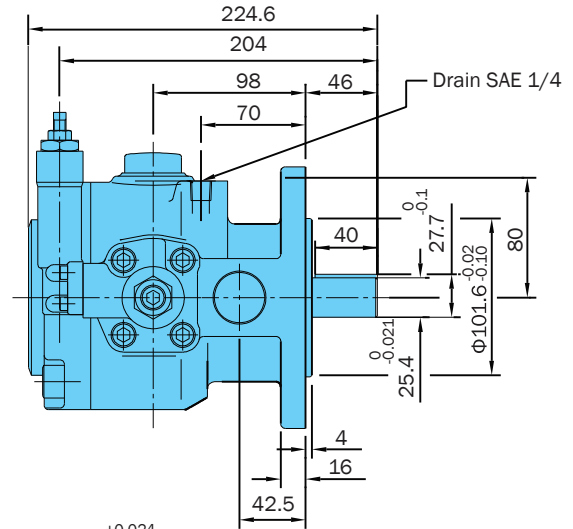
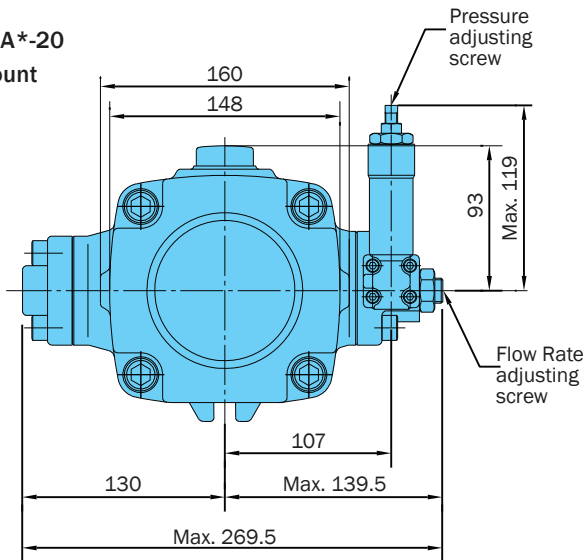

Installation Dimension Drawings

VDC-3A-1A*-20

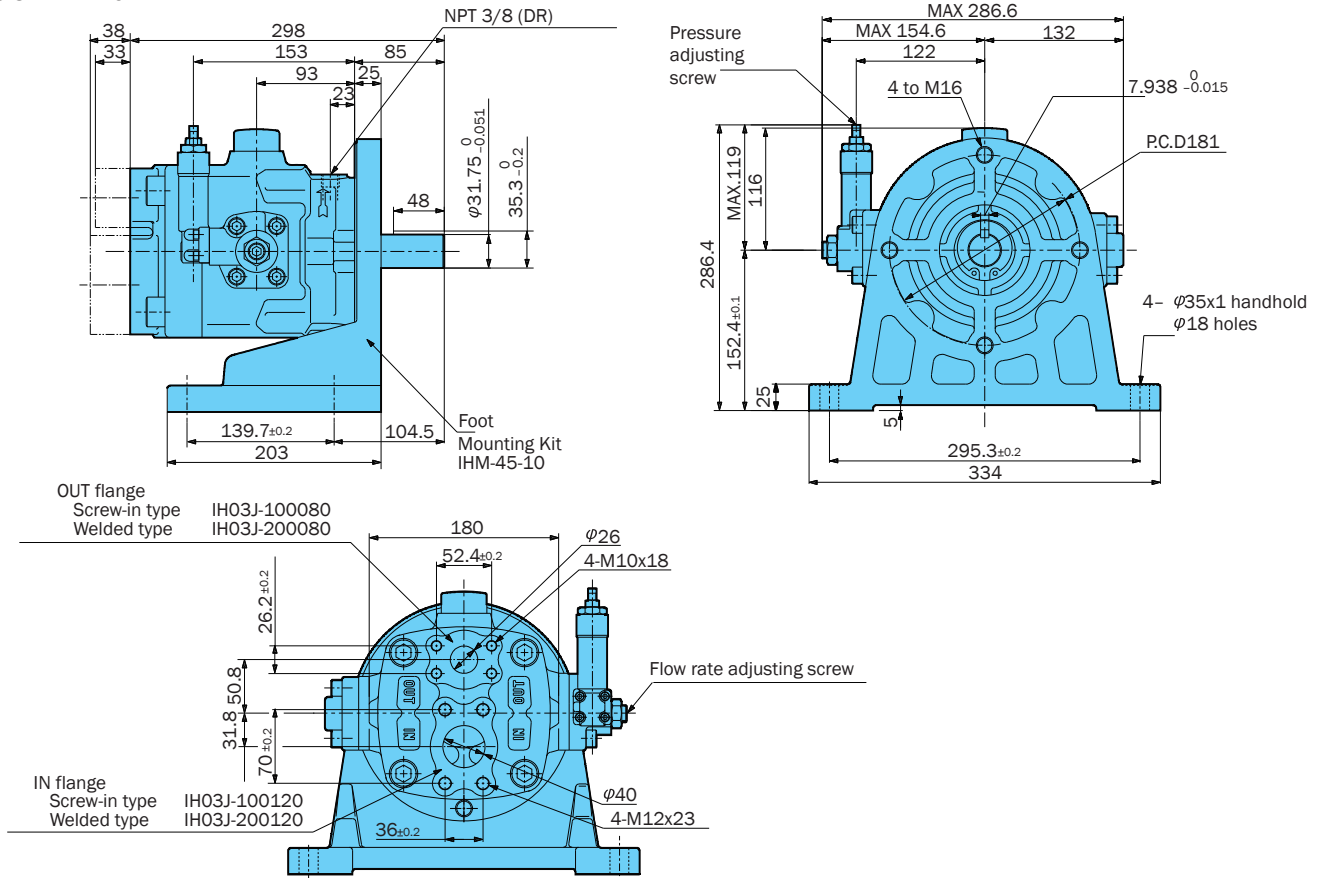

VDC-3B-1A*-E35

SAE C Mount

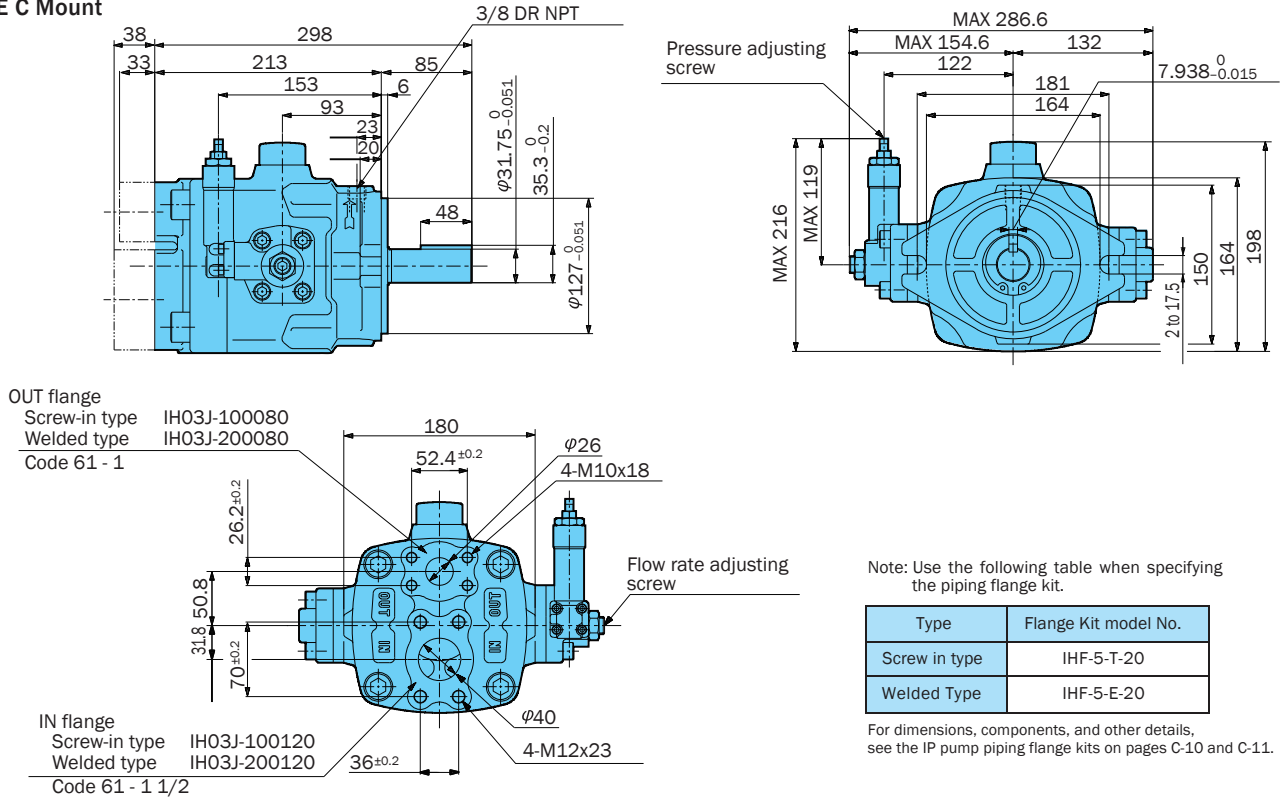

Note: Use the following table when specifying the piping flange kit.

Type	Flange Kit model No.
Screw in type	IHF-5-T-20
Welded Type	IHF-5-E-20

For dimensions, components, and other details, see the IP pump piping flange kits on pages C-10 and C-11.

**Double Pump
VDC-11B-*A**A*-E35**

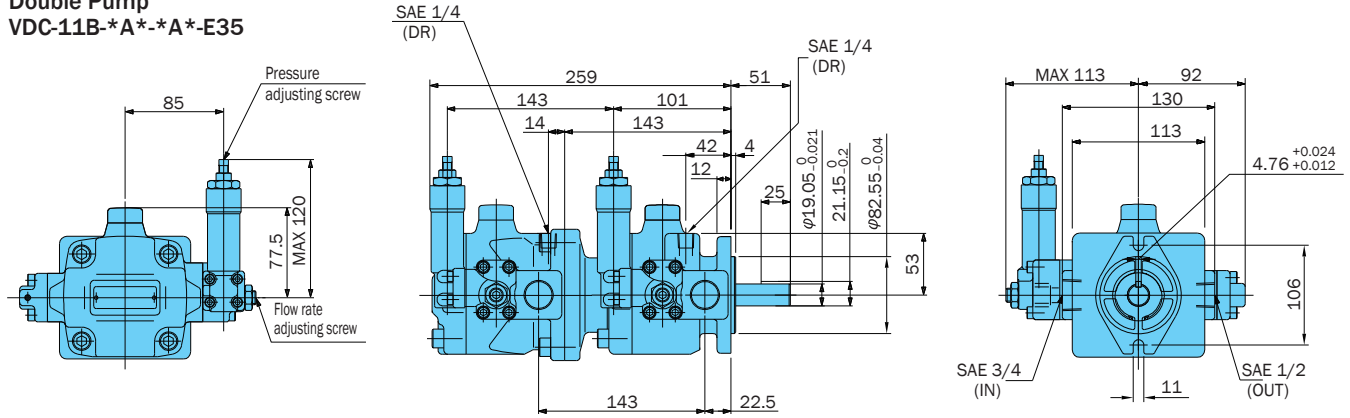

VDC-12B-*AA*-E35**

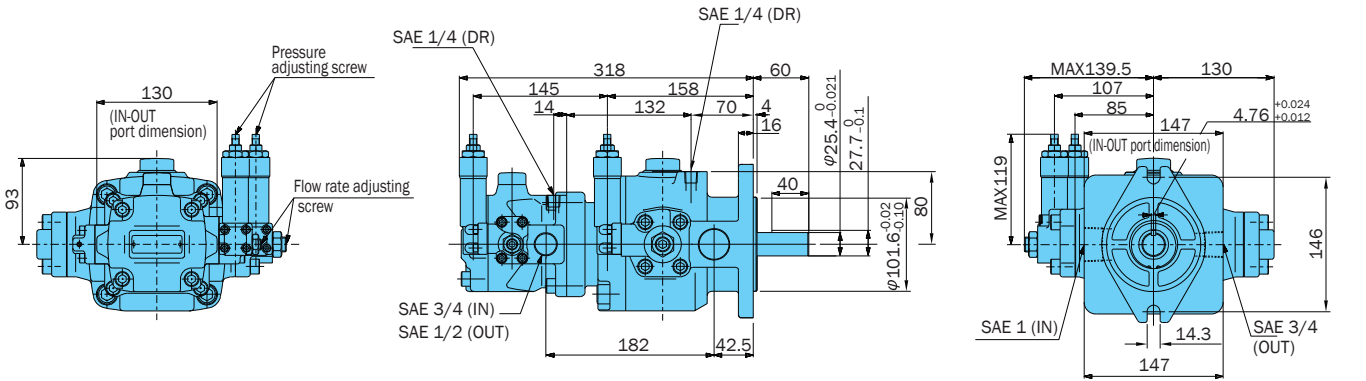

VDC-22B-*AA*-E35**

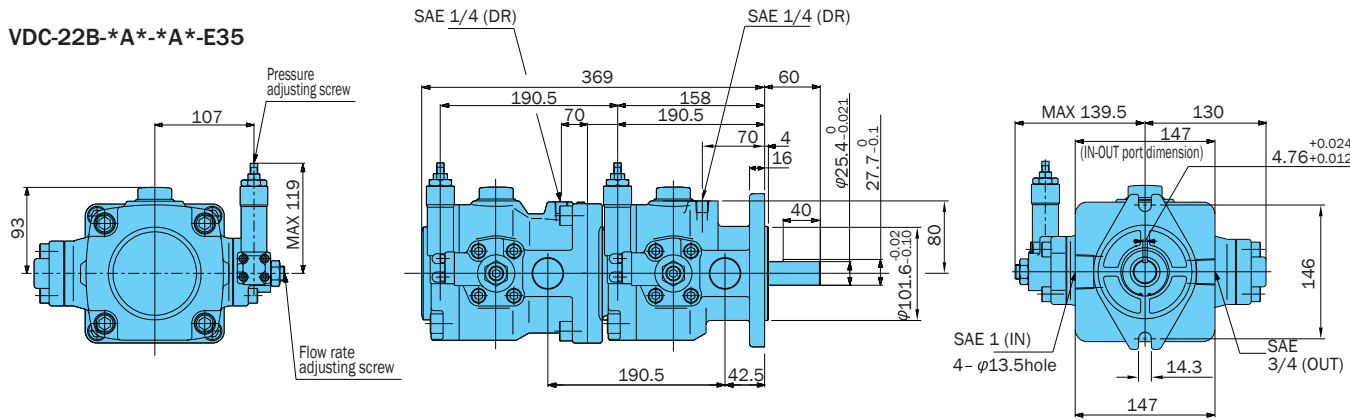

VDC-13B-*AA*-E35**

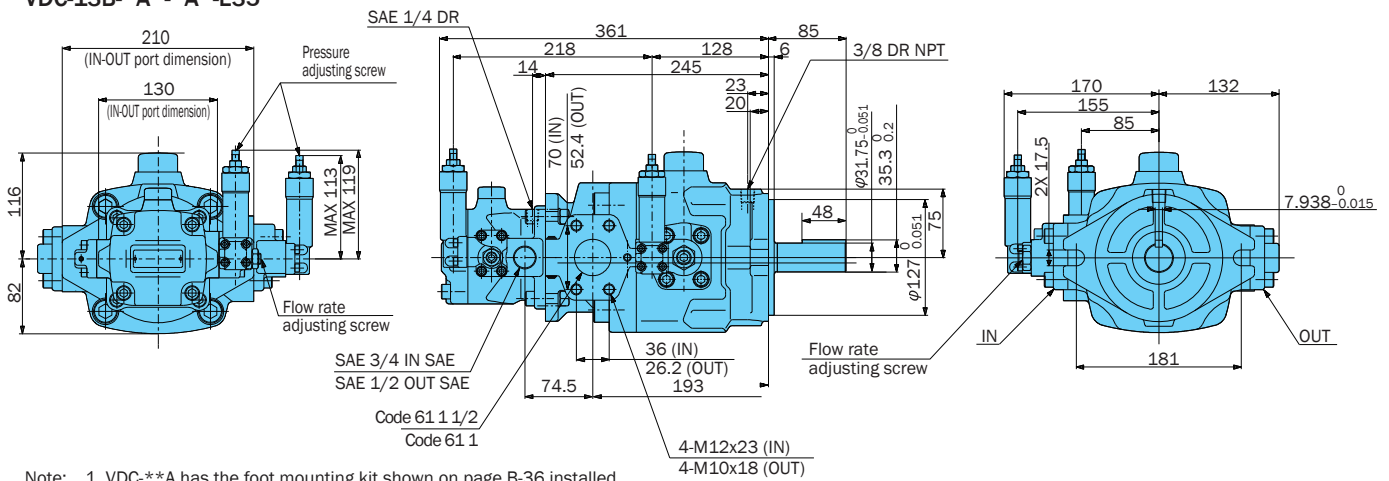

Note: 1. VDC-11B has the foot mounting kit shown on page B-36 installed.

Performance Curves

Typical characteristics at hydraulic operating fluid kinematic viscosity of 32 centistokes

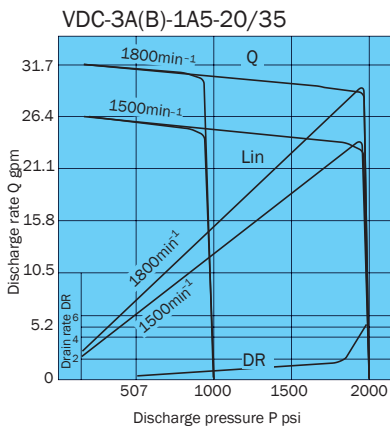
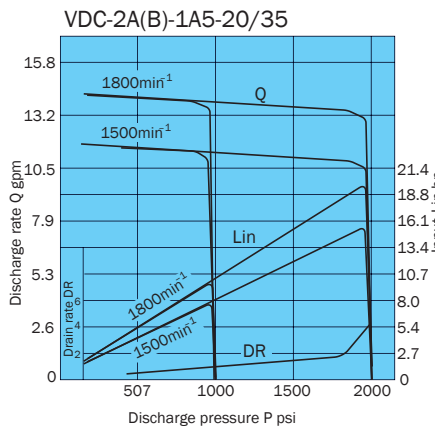
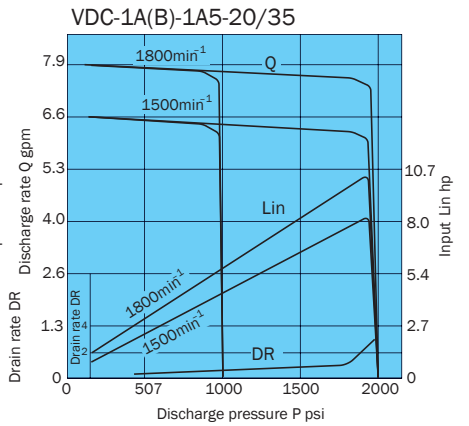
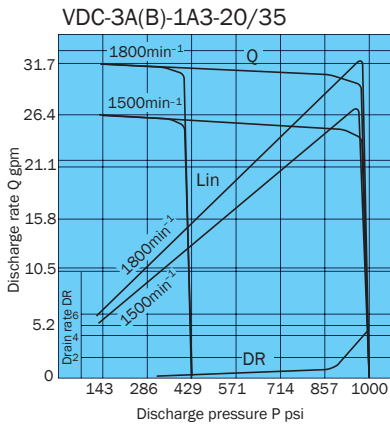
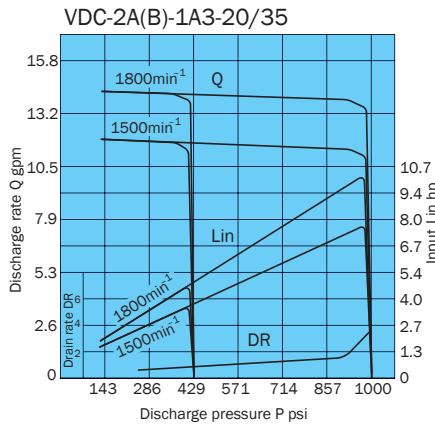
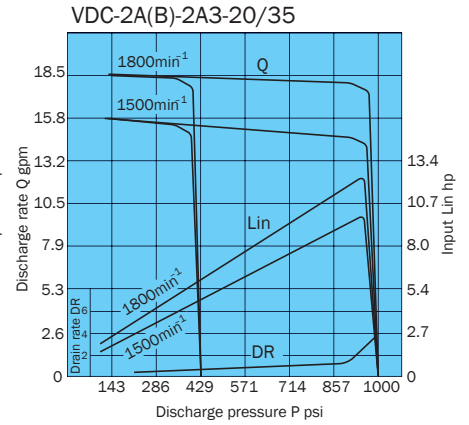
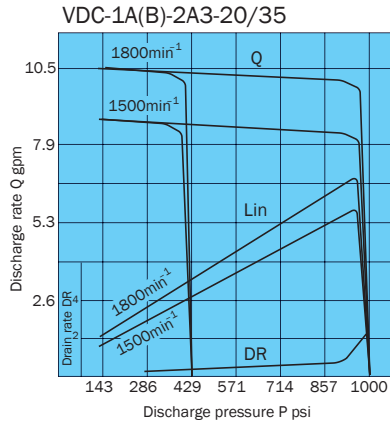
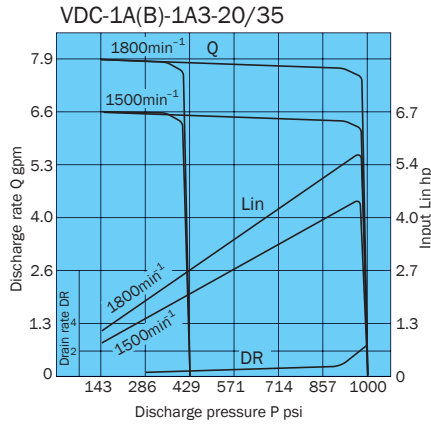

Axial input at full cutoff

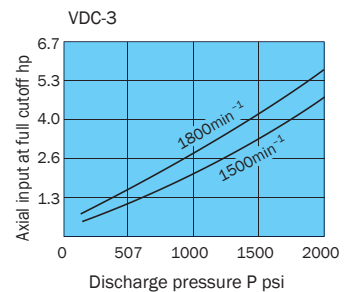
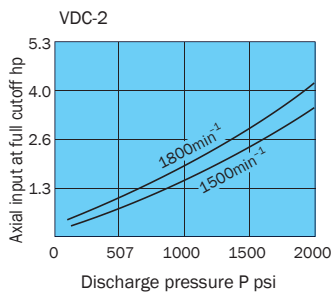
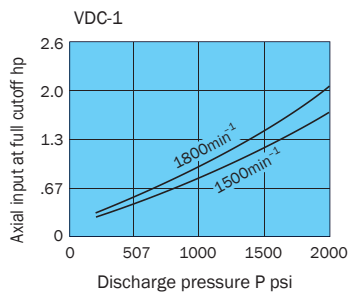

Noise Characteristics

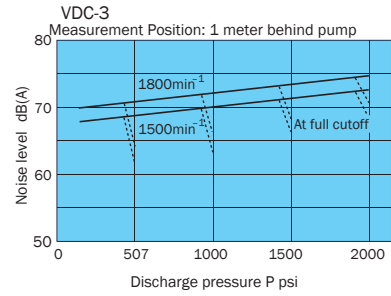
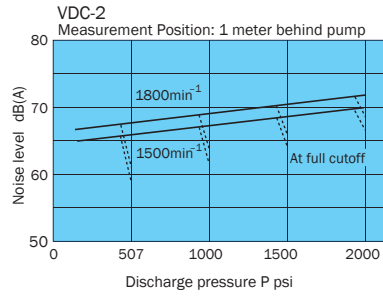
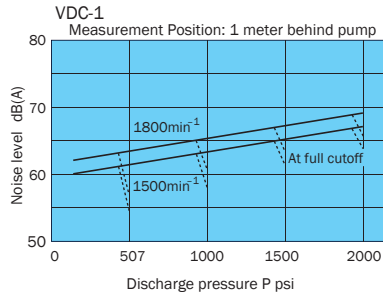

Cross-sectional Drawing

VDC-1A-*A*-20

VDC-2A-*A*-20

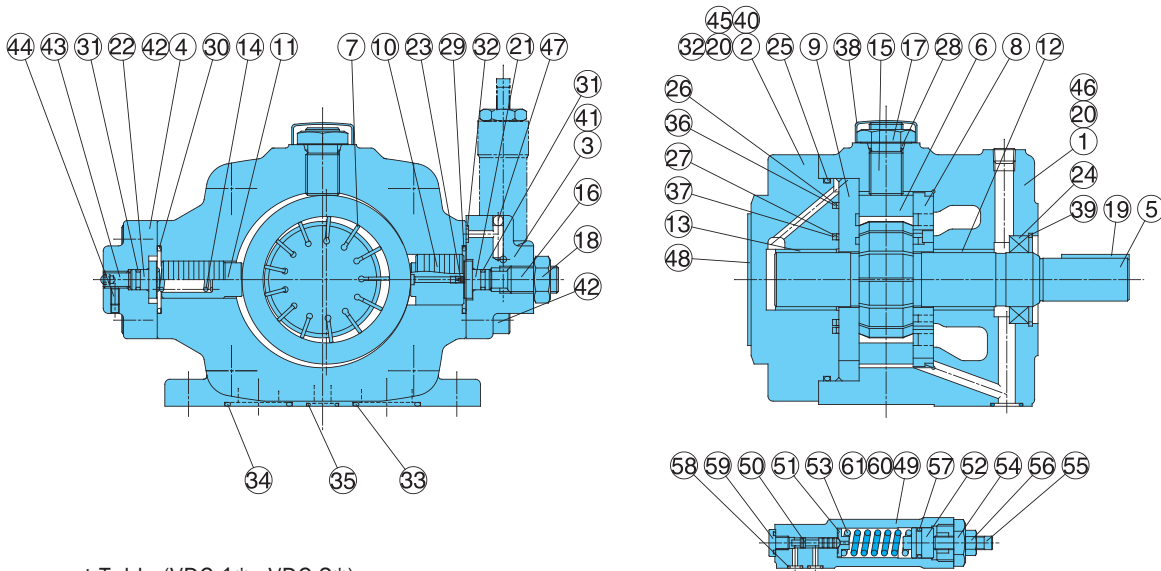

Seal Component Table (VDC-1*, VDC-2*)

Part No.	Applicable Pump Model No.	VDC-1A-*A*-20		VDC-2A-*A*-20	
	Seal Kit Number	VCBS-101A00		VCBS-102A00	
	Part Name	Part Number	Q'ty	Part Number	Q'ty
24	Oil seal	TCV-224211	1	TCN-325211	1
25	O-ring	S85(NOK)	1	1A-G115	1
26	O-ring	AS568-034	1	AS568-150	1
27	O-ring	AS568-026	1	AS568-134	1
28	O-ring	1A-P14	1	1A-P18	1
29	O-ring	1A-P22	1	1A-G35	1
30	O-ring	1A-P20	1	1A-G35	1
31	O-ring	1A-P5	2	1A-P9	2
32	O-ring	1A-P6	4	1A-P7	4
33	O-ring	1A-P25	1	1A-G35	1
34	O-ring	1A-P22	1	1A-G35	1
35	O-ring	1A-P10A	1	1A-P15	1
36	Backup ring	VCB34-101000	1	VCB34-102000	1
37	Backup ring	VCB34-201000	1	VCB34-202000	1
57	O-ring	1A-P14	1	1A-P14	1
58	O-ring	1B-P6(Hs90)	3	1B-P6(Hs90)	3

Note: 1. Oil seals are manufactured by Nippon Oil Seal Industry Co. Ltd. (NOK).
 2. O-ring 1A-** refers to JIS B2401-1A-**.
 3. For VDR-*B*-20, the seal kit number becomes VDBS-10*B00, without the 33, 24, and 35 O-rings.

Part No.	Part Name	Part No.	Part Name	Part No.	Part Name
1	Body (1)	21	Holder	41	Screw
2	Body (2)	22	Holder	42	Screw
3	Cover (1)	23	Orifice	43	Screw (stopper)
4	Cover (2)	24	Oil seal	44	Screw
5	Shaft	25	O-ring	45	Plug
6	Ring	26	O-ring	46	Plug
7	Vane	27	O-ring	47	Pole
8	Plate (S)	28	O-ring	48	Nameplate
9	Plate (H)	29	O-ring	49	Valve body
10	Piston (1)	30	O-ring	50	Spool
11	Piston (2)	31	O-ring	51	Holder
12	Bearing	32	O-ring	52	Plunger
13	Bearing	33	O-ring	53	Spring
14	Spring	34	O-ring	54	Retainer
15	Thrust screw	35	O-ring	55	Screw
16	Screw	36	Backup ring	56	Nut
17	Nut	37	Backup ring	57	O-ring
18	Nut	38	Cap	58	O-ring
19	Key	39	Snap ring	59	Plug
20	Pin	40	Screw	60	Plug
				61	Screw

Cartridge Kits:
 VDC-1 | VCBC-101*A*
 VDC-2 | VCBC-102*A*
 Includes Items: 5, 6, 7, 8, 9, 19, 20

Performance Curves

VDC-3A-1A*-20

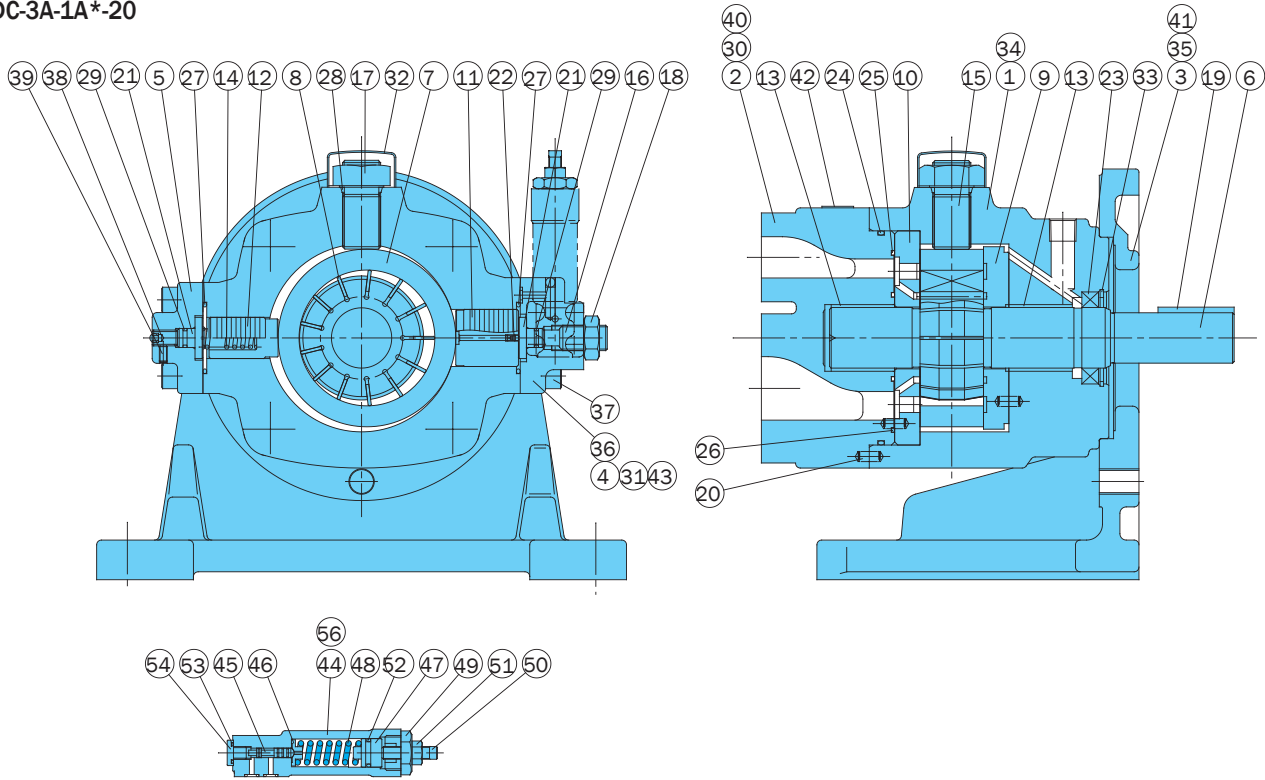

Seal Component Table (VDC-3*)

Part No.	Applicable Pump Model No. VDC-3A(B)*-20		
	Seal Kit Number VCBS-103B00		
	Part Name	Part Number	Q'ty
23	Oil seal	TCN-385811	1
24	O-ring	1A-G130	1
25	O-ring	AS568-154(Hs90)	1
26	O-ring	AS568-151(Hs90)	1
27	O-ring	1A-G40	2
28	O-ring	1A-P22	1
29	O-ring	1A-P9	2
30	O-ring	1A-P7	2
31	O-ring	1A-P7	2
52	O-ring	1A-P14	1
53	O-ring	1B-P6(Hs90)	3

Note: 1. Oil seals are manufactured by Nippon Oil Seal Industry Co. Ltd. (NOK).
2. O-ring 1A-** refers to JIS B2401-1A-**.

Part No.	Part Name	Part No.	Part Name	Part No.	Part Name
1	Body (1)	20	Pin	39	Screw
2	Body (2)	21	Holder	40	Plug
3	Mounting	22	Orifice	41	Washer
4	Cover (1)	23	Oil seal	42	Nameplate
5	Cover (2)	24	O-ring	43	Pole
6	Shaft	25	O-ring	44	Valve body
7	Ring	26	O-ring	45	Spool
8	Vane	27	O-ring	46	Holder
9	Plate (S)	28	O-ring	47	Plunger
10	Plate (H)	29	O-ring	48	Spring
11	Piston (1)	30	O-ring	49	Retainer
12	Piston (2)	31	O-ring	50	Screw
13	Bearing	32	Cap	51	Nut
14	Spring	33	Snap ring	52	O-ring
15	Thrust screw	34	Screw	53	O-ring
16	Screw	35	Screw	54	Plug
17	Nut	36	Screw	55	Plug
18	Nut	37	Screw	56	Screw
19	Key	38	Screw (stopper)		

Compensator Kits:

VDC-1 Thru -3 are same
VDC-A2 ZR-G01-A2-1688C
-A3 ZR-G01-A3-1688C
-A4 ZR-G01-A4-1688C
-A5 ZR-G01-A5-1688C
P-Remote ZR-G01-P-E1235A

Cartridge Kits:

VDC-1-20/35
VCBC-1011A2 (A2,A3)
VCBC-1011A4 (A4,A5)
VCBC-1012A2 (2A2,2A3)

VDC-2-20/35
VCBC-1021A2 (A2,A3)
VCBC-1021A4 (A4,A5)
VCBC-1022A2 (2A2,2A3)

VDC-3-20/35
VCBC-1031A2 (A2,A3)
VCBC-1031A4 (A4,A5)

Includes Items: 6, 7, 8, 9, 10, 19, 20

VDC Series
Double Pump

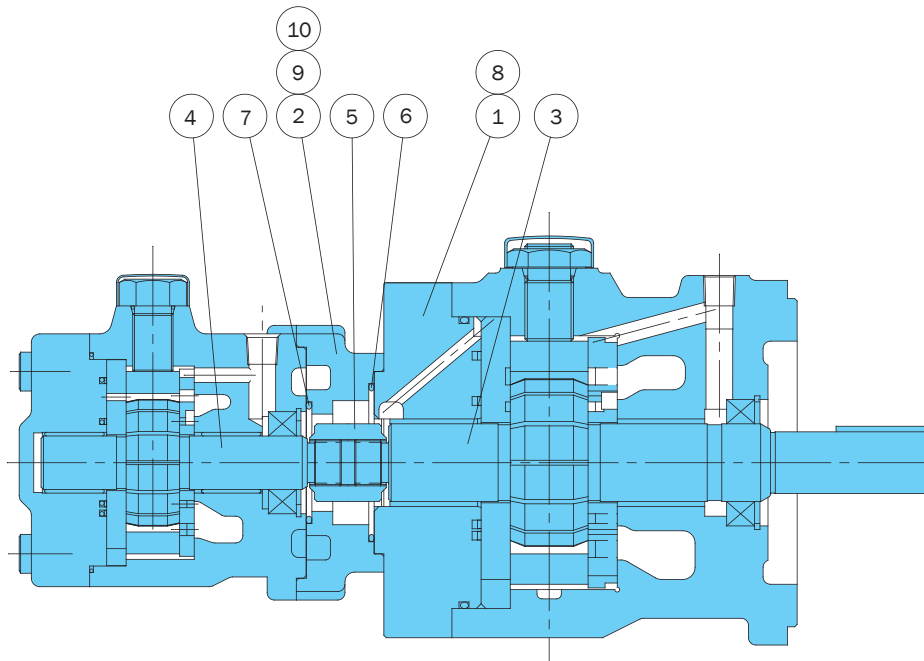

Part No.	Part Name
1	Body (2)
2	Body (3)
3	Shaft (S)
4	Shaft (H)
5	Joint
6	O-ring
7	O-ring
8	Screw
9	Screw
10	Screw

Note:
In the case of a double pump, use single pump parts in addition to the 10 parts listed above.

List of Sealing Parts

Part No.	Part Name	VDC-11A-*-*-20		VDC-12A-*-*-20		VDC-22A-*-*-20		VDC-13A-*-*-20	
		Part Number	Q'ty	Part Number	Q'ty	Part Number	Q'ty	Part Number	Q'ty
6	O-ring	☒		1A-G60	1	1A-G60	1	☒	
7	O-ring	1A-G85	1	1A-G45	1	1A-G60	1	1A-G85	1

Note: 1. See the description of the single pump for seal parts that are not included in the list.
2. O-ring 1A-** refers to JIS B2401-1A-**.

Foot Mounting Installation Measurement Chart

For VDC-11A, VDC-12 and VDC-22 (for double pump)

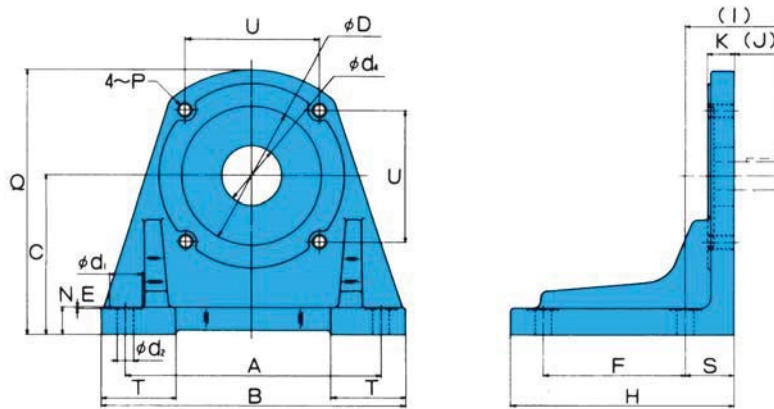

For VDC-3A and VDC-13A

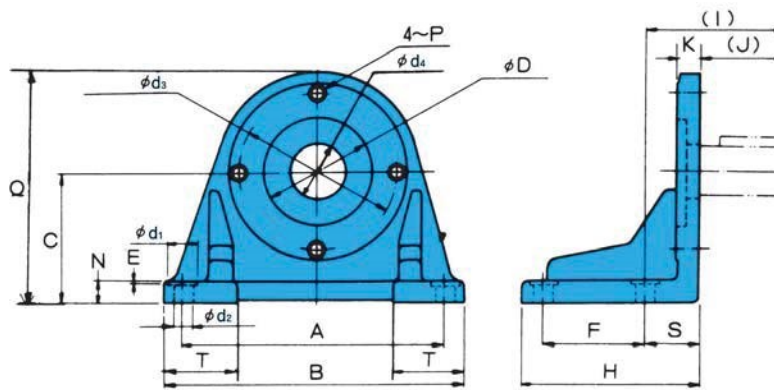

Foot Mounting Kit Model No.	Applicable Pump Model No.	Accessories				Dimensions (mm)					
		Bolt	Q'ty	Washer	Q'ty	A	B	C	E	F	H
VCM-11-20	VDC-1 (20) VDC-11 (20)	TH-10 × 30	4	WS-B-10	4	171.45	204	107.95	1	95.25	150
VCM-22-20	VDC-2 (20) VDC-12 (20) VDC-22 (20)	TH-12 × 35	4	WS-B-12	4	235	267	139.7	1	127	193
IHM-45-10	VDC-3 (20) VDC-13 (20)	TB-16 × 40	2	WP-16	2	295.3	334	152.4	1	139.7	203

Foot Mounting Kit Model No.	Dimensions (mm)														Weight lbs
	(I)	(J)	K	N	P	Q	S	T	U	φ D	φ d ₁	φ d ₂	φ d ₃	φ d ₄	
VCM-11-20	66.5	33	18	18	M10	180	32.5	50	90	95.02	22	11	∅	40	14.3
VCM-22-20	84.5	40	20	20	M12	232	44.5	57.5	124	135	22	14	∅	40	26.4
IHM-45-10	104.5	60	25	25	M16	259	44.5	61	∅	127	35	18	181	86	29.7

Uni-Pump Specifications

(CE mark standard compliant)

Single Pump

UVC - 1 A - 2 A 2 - 1.5 - 4 * 30

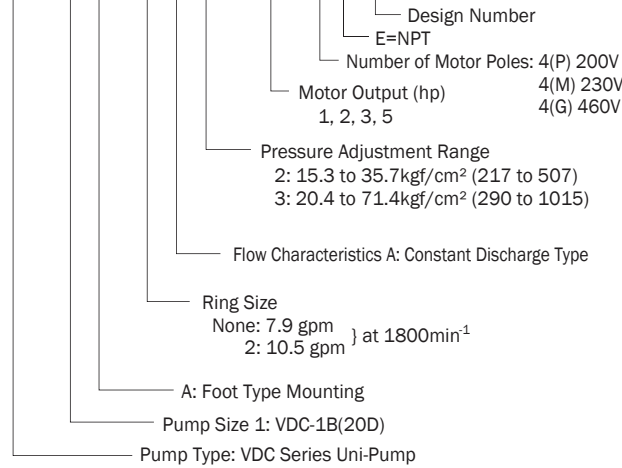

Double Pump

UVC - 11 A - 2 A 2 - 2 A 2 - 3.7 - 4 * 30

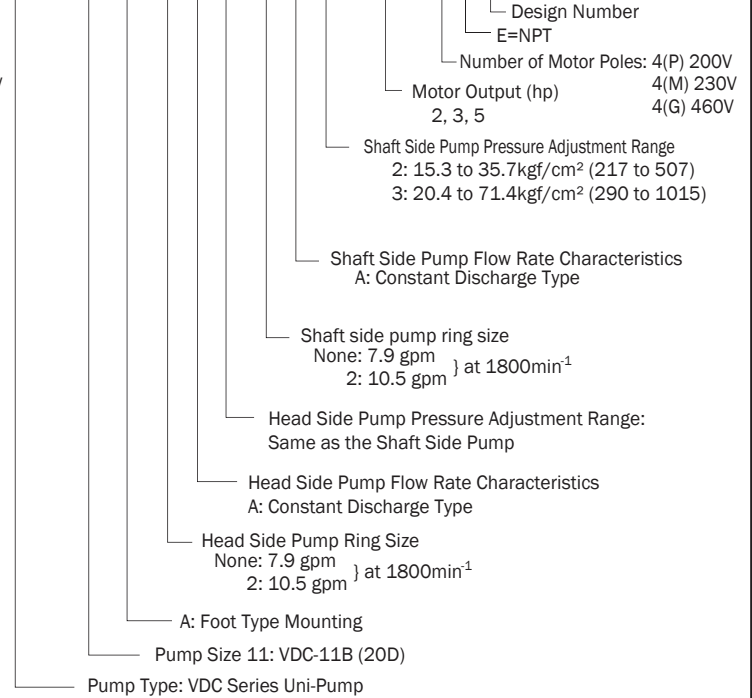

Specifications

Model No.	Maximum Working Pressure kgf/cm ² (psi)	Maximum Flow Rate gpm (A*)		Maximum Flow Rate gpm(2A*)	
		50Hz	60Hz	50Hz	60Hz
UVC- 1A UVC-11A	71.4 (1015)	6.6	7.9	8.7	10.3

Motor selection curves

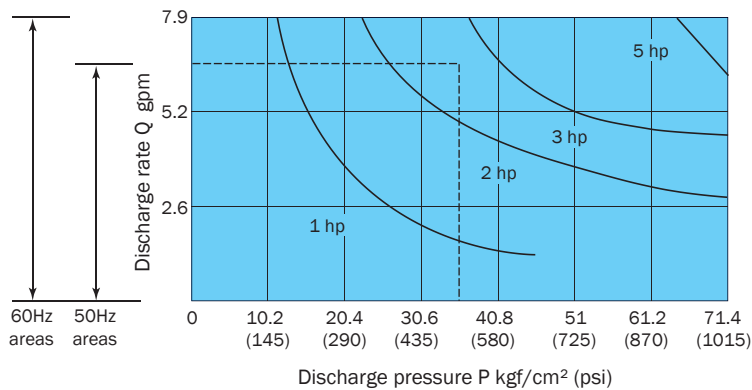

• Selecting a motor

The area under a motor output curve in the graph to the left is the operating range for that motor under the rated output for that motor.

Example:

To find the motor that can produce pressure of 507 psi and a discharge rate of 6.6 gpm.

Selection Process:

Since the intersection of the two broken lines from a pressure of 507 psi and discharge rate of 6.6 gpm intersect in the area under the 3 hp curve, it means that a 3 hp motor should be used. In the case of a double pump configuration, select a motor that is larger than the total power required by both pumps.

* Select a uni-pump that has a pressure and flow rate that is within the range of the drive so that the drive will not overload.

Installation Dimension Drawings

UVC-1A

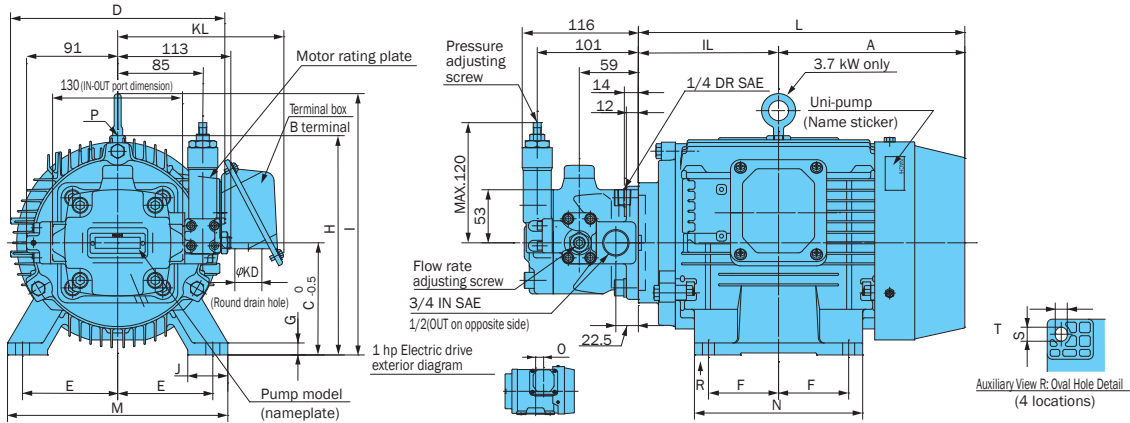

Uni-pump	Motor Dimensions mm																	Frame No.	Output hp (4 poles)	Weight lbs	
	A	IL	C	D	E	F	G	H	I	J	L	M	N	S *T	KD	KL	O				
UVC-1A-A2-0.75-4-30	133	105	80	170	62.5	50	4.5	165	-	35	238	165	130	18*10	ø27	157	27.5	80M	1	53	
UVC-1A-A2-1.5-4-30	143	118.5	90	198	70	62.5	10	190	-	40	261.5	176	150	12*10	ø27	159	-	90L	2	56	
UVC-1A-A3-1.5-4-30																					
UVC-1A-A2-1.5-4-30	157.5	133	100	198	80	70	12	200	-	40	290.5	200	168	14*12	ø27	159	-	100L	3	67	
UVC-1A-A3-2.2-4-30																					
UVC-1A-A2-2.2-4-30	186	140	112	214	95	70	12	-	261	40	326	220	168	14*12	ø27	166	-	112M	5	80	
UVC-1A-A3-3.7-4-30																					
UVC-1A-A4-3.7-4-30																					
UVC-1A-2A2-3.7-4-30																					
UVC-1A-2A3-3.7-4-30																					

0.75 to 2.2kW model does not have hangers.

- Standard drive motor is the fully enclosed fan-cooled B type.
- Standard voltage for drive motor is 200 VAC, 50/60 Hz or 220 VAC, 60 Hz.
- Standard terminal box is B terminal (right side viewed from pump).
- See page A-21 for the characteristics of the drive motor for the unipump (domestic standard 3 rating).

UVC-11A

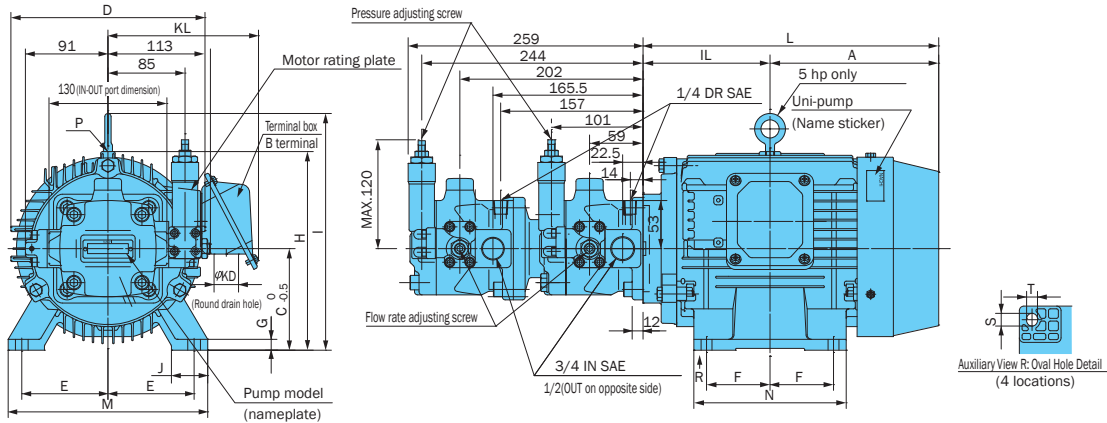

Uni-pump	Motor Dimensions mm																	Frame No.	Output hp (4 poles)	Weight lbs
	A	IL	C	D	E	F	G	H	I	J	L	M	N	S *T	KD	KL	O			
UVC-11A-A2-A2-1.5-4-30	143	118.5	90	198	70	62.5	10	190	-	40	261.5	176	150	12*10	ø27	159	90L	2	79	
UVC-11A-A2-A3-1.5-4-30																				
UVC-11A-A3-A3-1.5-4-30																				
UVC-11A-A2-A2-2.2-4-30	157.5	133	100	198	80	70	12	200	-	40	290.5	200	168	14*12	ø27	159	100L	3	90	
UVC-11A-A3-A3-2.2-4-30																				
UVC-11A-A2-A2-2.2-4-30	186	140	112	214	95	70	12	-	261	40	326	220	168	14*12	ø27	166	112M	5	103	
UVC-11A-A2-A3-3.7-4-30																				
UVC-11A-A3-A3-3.7-4-30																				
UVC-11A-2A2-2A2-3.7-4-30																				
UVC-11A-2A2-2A3-3.7-4-30																				

No hanger on 2 and 3 hp models.

- Standard drive motor is the fully enclosed fan-cooled B type.
- Standard voltage for drive motor is 200 VAC, 50/60 Hz or 220 VAC, 60 Hz.
- Standard terminal box is B terminal (right side viewed from pump).
- See page A-21 for the characteristics of the drive motor for the unipump (domestic standard 3 rating).